



heritage



Article

Interdisciplinary Analysis of Water UBH: The *Palombaro Purgatorio* *Vecchio* Infrastructure in Matera

Daniele Altamura, Giandamiano Fiore, Angelarosa Manicone, Enrico Lamacchia, Arcangelo Priore,
Nicola Masini, Ruggero Ermini, Antonella Guida and Graziella Bernardo

Special Issue

Exploring Underground Built Heritage

Edited by

Dr. Carlos Smaniotto Costa and Dr. Marlucci Menezes



<https://doi.org/10.3390/heritage9030102>

Article

Interdisciplinary Analysis of Water UBH: The *Palombaro Purgatorio Vecchio* Infrastructure in Matera

Daniele Altamura ^{1,*}, Giandamiano Fiore ^{2,3}, Angelarosa Manicone ¹, Enrico Lamacchia ^{1,3},
Arcangelo Priore ¹, Nicola Masini ³, Ruggero Ermini ¹, Antonella Guida ¹ and Graziella Bernardo ¹

¹ Department for Humanistic, Scientific and Social Innovation, University of Basilicata, via Lanera 10, 75100 Matera, Italy; angelarosa.manicone@unibas.it (A.M.); enrico.lamacchia@unibas.it (E.L.); arcangelo.priore@unibas.it (A.P.); ruggero.ermini@unibas.it (R.E.); antonella.guida@unibas.it (A.G.); graziella.bernardo@unibas.it (G.B.)

² Department of Sciences of Antiquities, Sapienza University of Rome, Piazzale Aldo Moro, 5, 00185 Rome, Italy; giandamiano.fiore@uniroma1.it

³ National Research Council (CNR)—Institute of Sciences of Cultural Heritage (ISPC) CNR-ISPC, Contrada Loya, 85050 Tito, Italy; nicola.masini@cnr.it

* Correspondence: daniele.altamura@unibas.it; Tel.: +39-3884459197

Abstract

Historical water management infrastructures, often comprising underground environments, represent a significant example of the interplay between built heritage and the natural substrate. This study proposes an interdisciplinary, integrated and multi-scalar investigative methodology for such structures. Through the analysis of the case study of *Palombaro Purgatorio Vecchio*, a large historical public water cistern located in Matera in Italy, this paper presents a rigorous methodology replicable in different contexts. Bibliographic and archival research establish the knowledge base regarding the structure's historical evolution; territorial and hydromorphic analyses, supported by GIS, highlight the dynamics of the surrounding watersheds. Meanwhile, a digital survey integrating SLAM and photogrammetry provides geometric-dimensional data, serving as the foundation for analysing construction techniques and materials. The selection of accessible and manageable technologies promotes a practical, replicable investigative methodology aimed at the protection, comprehension, enhancement and dissemination of water UBH.

Keywords: underground built heritage; interdisciplinary analysis; historical water infrastructures; 3D digital survey; historical materials and techniques



Academic Editors: Carlos Smaniotto Costa and Marlucci Menezes

Received: 30 January 2026

Revised: 24 February 2026

Accepted: 26 February 2026

Published: 4 March 2026

Copyright: © 2026 by the authors.

Licensee MDPI, Basel, Switzerland.

This article is an open access article distributed under the terms and conditions of the [Creative Commons Attribution \(CC BY\) license](https://creativecommons.org/licenses/by/4.0/).

1. Introduction

Underground built heritage (UBH) encompasses anthropogenic structures and infrastructures located in subterranean environments, created through excavation or combined excavation and masonry techniques. Including rock-cut dwellings, quarries, hypogeal religious spaces, and hydraulic systems, UBH preserves evidence of long-term settlement, production, and infrastructural practices. As an integral component of cultural heritage, it embodies historical, technical, social, and identity values, often reflecting the interplay between geological conditions, natural resources, and human adaptive strategies.

Despite its significance, UBH is affected by a dual inaccessibility. On the one hand, it remains culturally and epistemically underexplored, with limited documentation, analysis, and dissemination compared to above-ground heritage, resulting in persistent knowledge gaps. On the other hand, it presents material and operational challenges, as underground

environments are difficult to access and survey due to safety constraints and adverse conditions—such as the absence of natural light, high humidity, confined spaces, and restricted mobility—which hinder complex data acquisition processes.

Addressing these limitations requires systematic documentation and analysis to support conservation and valorisation. In this context, digital technologies have become fundamental, with the scientific community consolidating rigorous methodologies based on terrestrial laser scanning and photogrammetry, capable of ensuring high geometric accuracy. Given the constraints of hypogeal environments, research has emphasised multi-sensor approaches, metric control, and validation procedures. Notable examples include the integrated documentation of Palaeolithic caves in Asturias [1] and the multi-scale survey of the Les Fraux cave [2], both demonstrating the effectiveness of combining complementary acquisition techniques.

More recently, methodological advancements have focused on efficiency through mobile mapping systems and SLAM-based technologies [3–6], particularly suited to complex, GNSS-denied environments. Studies specifically addressing UBH have highlighted both the potential and limitations of these approaches, stressing the importance of trajectory planning, loop closure, and reliability assessment to ensure robust 3D datasets [7], as well as the need to control drift in rapid acquisition workflows [8]. Within this evolving framework, the use of non-professional devices—especially smartphones—represents a promising yet still underexplored frontier, enabling broader access to documentation processes and fostering the democratisation of heritage knowledge [9]. Recent studies have proposed low-cost photogrammetric and videogrammetric workflows, identifying critical issues such as motion blur, exposure control, repetitive geometries, and low-light performance [10], while quantitative assessments have demonstrated that within a fit-for-purpose perspective, such methods can yield acceptable results [11].

This study aims to demonstrate that accessible technologies, when embedded within a rigorous methodological framework and applied with awareness of their limitations, can produce reliable outcomes for the knowledge and enhancement of UBH, with particular reference to hydraulic systems. The karst landscape of Matera provides a significant case study, where human adaptation to environmental conditions has generated an integrated system of excavated spaces, channels, and cisterns for water management.

Within this context, the *Sassi* preserve an exceptional network of underground infrastructures for water interception, conveyance, decantation, and storage, recognised as a UNESCO World Heritage Site (1993). Among these, the *palombari*—monumental excavated cisterns—represent outstanding examples of hydraulic architecture, conceived as public infrastructures for water collection and fundamental to the functioning of the historic urban system [12].

The research proposes an interdisciplinary and replicable methodological framework based on a multi-scale analysis integrating historical-evolutionary, geographical, urban, architectural, hydraulic, and material-constructive aspects. The *Palombaro Purgatorio Vecchio* (Figure 1) was selected as a representative case study due to its exceptional historical and architectural significance. Its analysis enables a critical interpretation of the urban evolution of Matera, highlighting how the construction and use of such infrastructures are intrinsically linked to local morphological, geological, and hydrological conditions. In this perspective, the *palombari* respond to the need for efficient water management within a complex environment and provide key insights into settlement dynamics, revealing the structural relationship between terrain morphology, water availability, and historical habitation patterns [12].

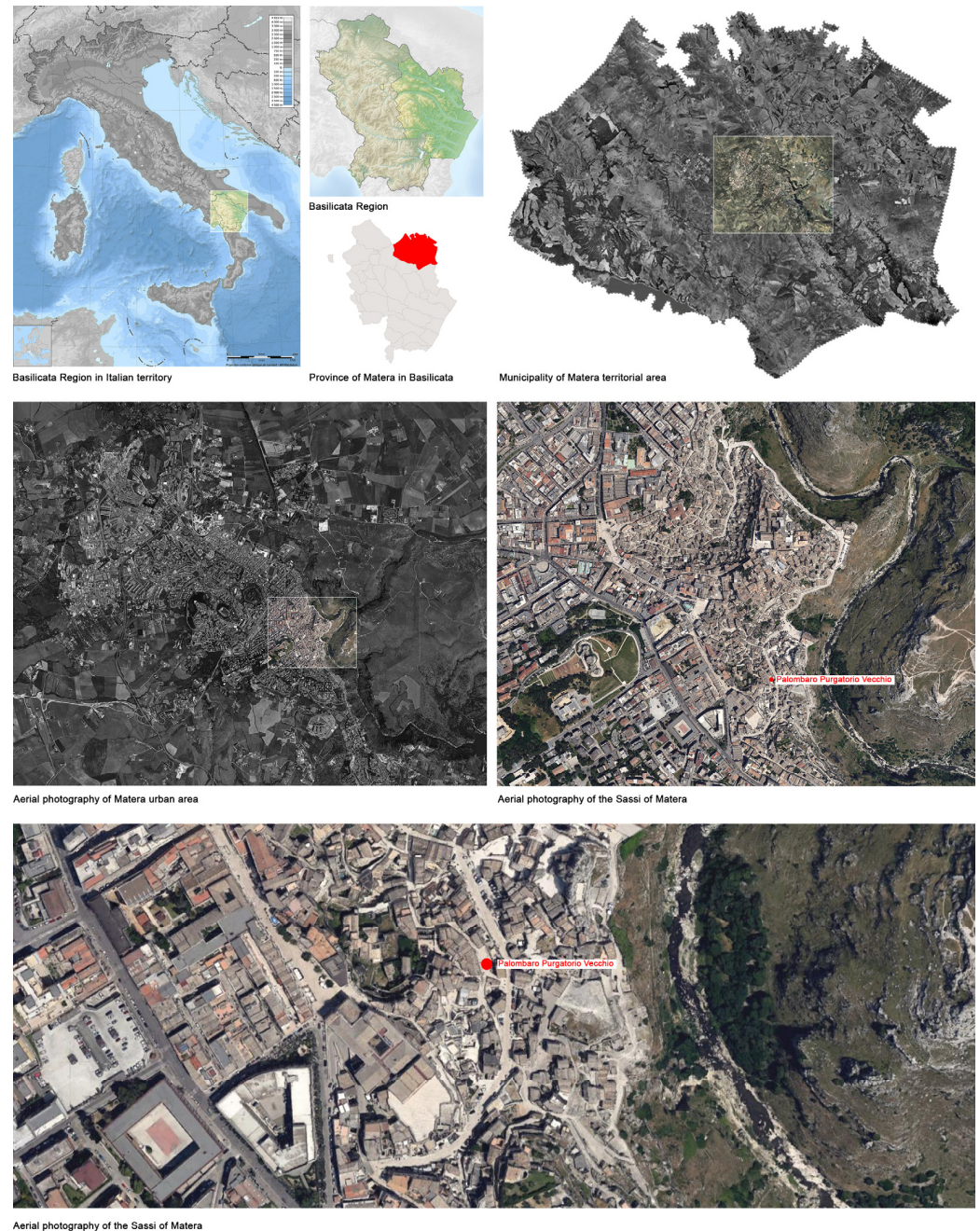

Figure 1. Geographic setting of the historical *Palombaro Purgatorio Vecchio* infrastructure.

Consequently, the investigation of this heritage emerges as a priority, providing a knowledge base for future strategies of conservation, enhancement, and adaptive reuse.

2. Materials and Methods

The research is structured in three macro-steps, organised according to an integrated methodological sequence (Figure 2), designed to ensure replicable interdisciplinary and multi-scale knowledge for historic water infrastructures. Indirect Knowledge is devoted to the reconstruction of preliminary knowledge, which is foundational for comprehending the general aspects of the object under scrutiny. In this context, Archival Research and a Systematic Literature Review, together with the critical analysis of documentary sources and geographical context, allow for the construction of a robust historical and thematic framework, which is an essential prerequisite for any historical-evolutionary reconstruction.

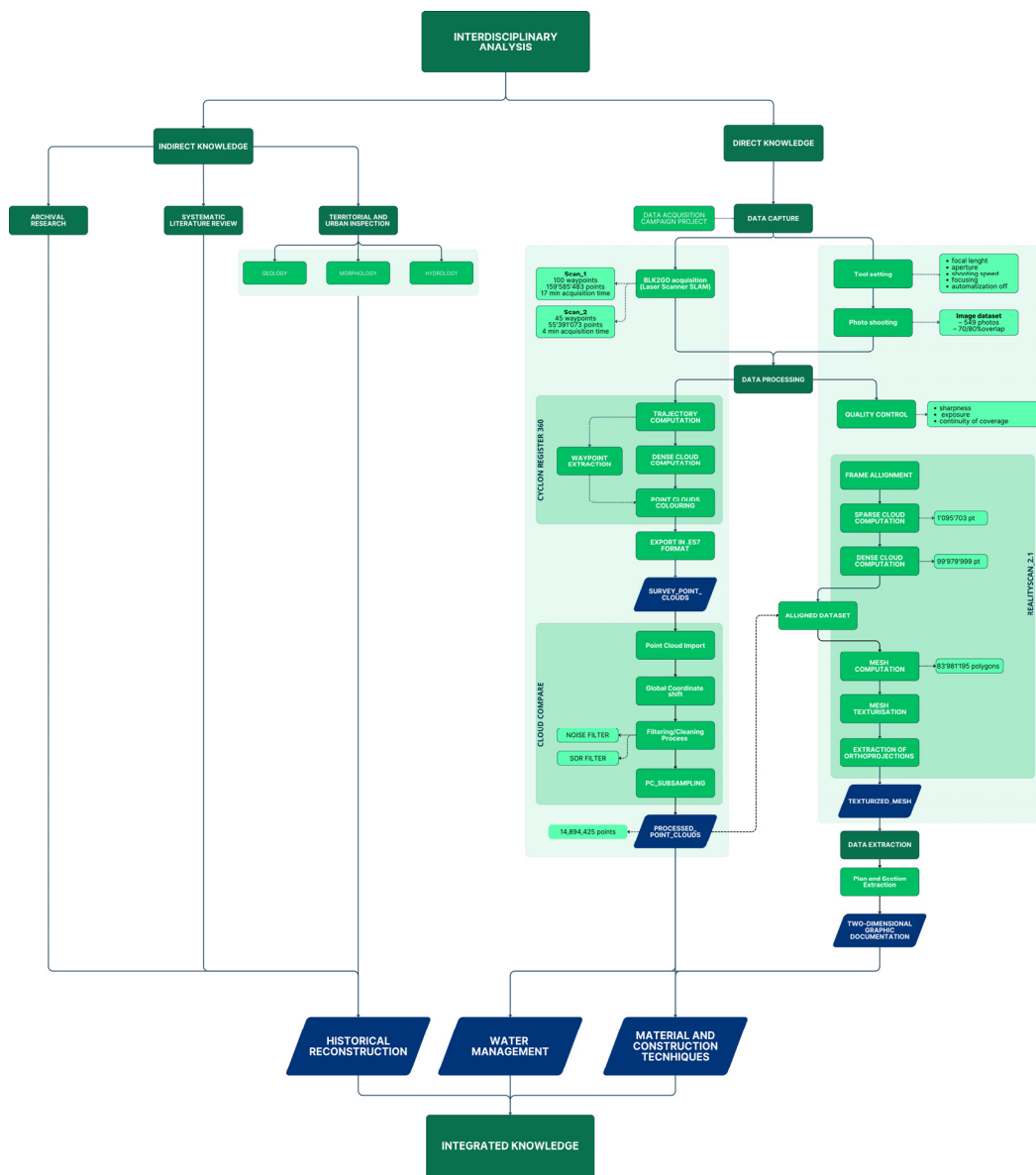

Figure 2. Methodological Workflow.

In Indirect Knowledge, it is imperative to undertake a thorough examination of the extant documentation pertaining to urban water management. This should be complemented by preliminary research addressing Territorial and Urban Inspection, encompassing the geology, morphology, as well as the hydrology that influence the study area.

Direct Knowledge is supported by advanced digital technologies and is articulated into three interconnected steps: Data Capture, Data Processing, and Data Extraction [13]. Data Capture consists of on-site surveys carried out through the integrated use of Image-Based Modelling (IBM) and Range-Based Modelling (RBM), aimed at acquiring high-resolution datasets, alongside the collection of material samples for stratigraphic analysis. Data Processing entails the filtration, optimisation and integration of data through the utilisation of specialised softwares. This progression occurs from raw point clouds to processed datasets and ultimately to a textured mesh, resulting in an accurate and functional three-dimensional model. This model serves not only as a representation of the current state but also as an analytical tool for investigating material, structural, and hydraulic dynamics. Finally, Data Extraction enables the production of two-dimensional drawings, geometric information, and the interpretation of the hydrological context and water management system.

Within Integrated Knowledge, the outcomes of the previous steps are synthesised into a coherent interpretative framework. The integration of Indirect and Direct Knowledge enables complementary results: the former supports the historical reconstruction of the system and its diachronic evolution, while the latter provides the analytical basis for understanding water management practices, usage patterns, and material and construction techniques. This approach allows for a comprehensive interpretation that combines historical, functional, and constructive analyses within a unified methodological framework.

Overall, the process demonstrates that the proposed integrated, multi-scale methodology constitutes a robust and replicable model for the study of underground built heritage.

2.1. Indirect Knowledge

The step of Indirect Knowledge acquisition was developed through a structured process of bibliographic and archival research, with the aim of reconstructing the historical, technical and cultural framework of the water underground built heritage (Figure 3), with particular reference to the public cistern known as *Palombaro Purgatorio Vecchio*.

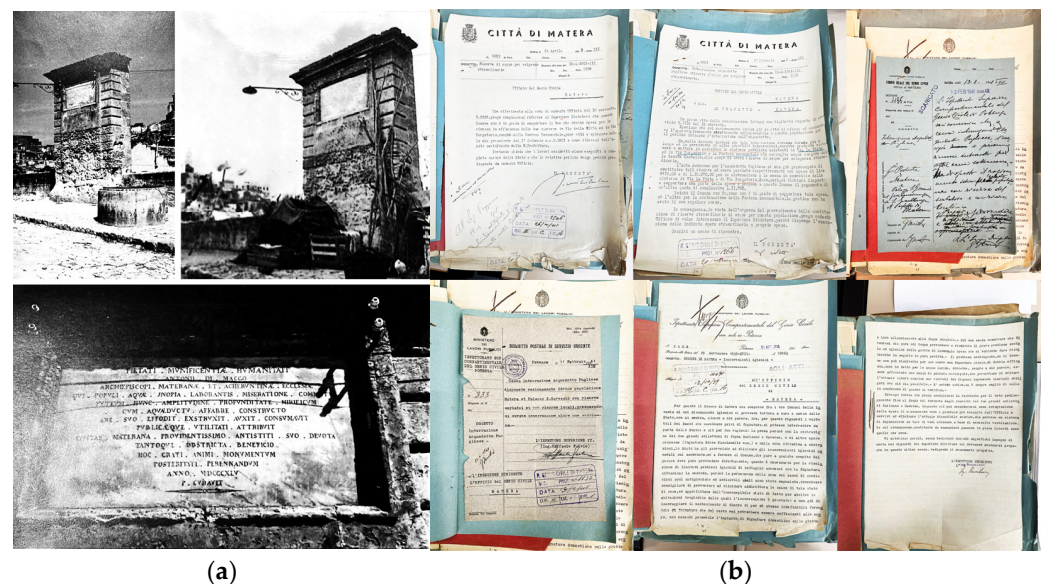

Figure 3. (a) Photographs of the commemorative monument of *Palombaro Purgatorio Vecchio* consulted at the private archive of the Mattia Antonio Acito Architect. (b) Photographs of the historical documents consulted at the State Archive of Matera.

2.1.1. Archival Research and Systematic Literature Review

The bibliographic analysis was grounded in a preceding systematic literature review [14] that established the theoretical and methodological framework for the entire research endeavour. This review enabled the identification of the principal lines of inquiry, recurrent disciplinary approaches, and existing knowledge gaps concerning the relationship between Matera and water, as well as its underground hydraulic heritage.

Concurrently, archival research constituted a pivotal element in achieving historical and documentary comprehension of the structure. The investigation was carried out in several archival institutions, selected according to the typology and relevance of the preserved sources: the Municipal Historical Archive of Matera, the State Archive of Matera, the Diocesan Archive, the private archive of Mattia Antonio Acito and the Archive of the Superintendency.

The analysis of the collected documents encompassed administrative records, cartographic sources, technical documentation, historical accounts, and interpretative materials, allowing for the reconstruction of the phases of construction, management, and transfor-

mation of the underground water system, as well as the role of the cistern within the urban and social context. The critical integration of bibliographic and documentary sources was instrumental in consolidating the knowledge base of the case study, thereby providing essential support for the subsequent steps of direct and interdisciplinary analysis.

2.1.2. Territorial and Urban Inspection: Geology, Morphology and Hydrology

The territorial analysis was conducted through the examination of a Digital Elevation Model (DEM) obtained from the RSDI Basilicata platform [15], with subsequent processing carried out using QGIS 3.4.13 [16] and GRASS GIS 7.2.0 [17]. These tools enabled a detailed investigation of the morphological and hydrological characteristics of the study area, supporting the derivation of a consistent representation of potential hydrography. Hydrological modelling based on DEMs is widely acknowledged as a robust and replicable approach for territorial, environmental, and landscape analyses. Nevertheless, its reliability is strongly contingent upon the resolution and quality of the Digital Terrain Model (DTM), as well as on the methodological choices adopted, all of which must be explicitly documented in scientific applications [18].

Within this framework, the extraction of hydrographic networks from the DTM follows a sequence of well-established raster-based hydrological procedures grounded in the fundamental assumption that topography governs surface runoff [19]. The initial phase involves the hydrological correction of the DTM through the removal of spurious depressions (sinks), which are recognised as a primary source of error in the delineation of drainage systems. The application of pit-filling or depression-breaching algorithms is therefore considered an essential prerequisite for ensuring flow continuity and analytical reliability [18].

Subsequently, flow direction is computed by assigning each raster cell the direction of steepest descent, a fundamental step in hydrological modelling. Building upon this, flow accumulation is calculated to quantify the upstream contributing area for each cell. This parameter is crucial for identifying drainage pathways, as high accumulation values typically correspond to valley bottoms and zones of concentrated runoff [19]. The hydrographic network is then delineated by applying an accumulation threshold, which defines the minimum contributing area required for a flow path to be classified as a channel. The selection of this threshold represents a critical methodological decision, closely related to the DTM resolution and the spatial scale of analysis [20,21].

The resulting drainage network, initially generated in raster format, can be converted into vector data to facilitate advanced spatial analyses and comparisons with existing cartographic or observed hydrographic features. In parallel, the delineation of drainage basins is achieved by integrating flow direction data with predefined outlet points, thereby identifying the areas contributing runoff to specific closure sections. This DEM-based approach to basin delineation has become a standard methodology in hydrological and quantitative geomorphological research [20,21].

2.2. Direct Analysis: Data Acquisition, Data Processing and Data Extraction

The intricacy of the architectural heritage, wherein each artefact represents a distinct case due to historical modifications and stratifications over time, necessitates a knowledge-based and conservation-oriented approach capable of identifying, safeguarding and enhancing the identity-defining features and intrinsic values [22]. In this context, knowledge processes supported by innovative digital data-acquisition techniques must account for site-specific characteristics, delivering high-resolution and accurate datasets within limited timeframes [3].

The Data Acquisition process commences with the design of the survey campaign, which is pivotal to the success of data collection. The definition of the level of detail, precision and accuracy required is crucial for selecting acquisition techniques and defining alignment strategies for different datasets. Concurrently, analysis of the operational context, environmental conditions and preliminary inspections allows for the assessment of constraints and critical issues that may affect geometric and informational quality, as well as the final graphic output.

Within the decision-making framework, the literature identifies two methodologies for documenting built heritage that are capable of generating 3D models from in situ data (Figure 2): image-based modelling (IBM) and range-based modelling (RBM). IBM analyses two-dimensional images using Structure from Motion (SfM) and Multi-View Stereo (MVS) algorithms to reconstruct high-resolution 3D models. RBM employs active sensors on static or mobile devices to measure distances and produce precise 3D models within reduced timeframes [23]. Compared with static devices such as Terrestrial Laser Scanners (TLSs), mobile SLAM-based systems offer shorter acquisition times and greater spatial coverage.

RBM systems based on SLAM consist of a frontend module for real-time data acquisition and motion estimation, and a backend module that optimises mapping and pose estimation, correcting drift errors and ensuring consistency and accuracy [3]. However, although RBM ensures high metric accuracy and operational efficiency, it presents limitations in surface graphic detail, particularly in representing textures, colours, and micro-surface features essential for material interpretation and conservation analysis [3].

Digital photogrammetry through SfM enables the production of 3D models with high visual detail and photorealistic appearance. Compared with laser systems, the image-based approach is particularly effective for documenting surfaces due to the association of chromatic information with geometric elements [23]. However, photogrammetry is more sensitive to lighting conditions, surface texture and repetitive geometries and, if used alone, may be less reliable metrically.

Integration of SLAM and photogrammetry enables the leveraging of the strengths inherent in both technologies, resulting in a synergistic effect. This integration allows for the utilisation of the metric robustness and spatial coherence of laser surveying, alongside the informational and graphic richness of photogrammetric data. Operationally, the SLAM point cloud can be used as a metric reference and constraint system for registering and scaling the photogrammetric model. This process allows the creation of a final 3D model that is more accurate, readable, and suitable for multiple analytical and conservation purposes [3].

The decision to adopt cost-effective and efficient processes, utilising a non-professional camera, is driven by the necessity to enhance the accessibility and replicability of the digitalisation process. Modern cameras integrated into smartphones offer high-resolution sensors, advanced stabilisation systems, and an image quality that is generally adequate for photogrammetric applications in the architectural domain, especially when supported by a correct acquisition workflow [24].

The primary advantage of this choice is the substantial reduction in costs, the expedited acquisition process, and the ease of use, which facilitate operation in complex or inaccessible contexts. Furthermore, the high chromatic quality of the images facilitates the production of detailed textures, which are conducive to material interpretation and qualitative analyses. In contrast, limitations are associated with diminished control over optical parameters in comparison to professional cameras, heightened sensitivity to lighting conditions (a critical consideration in indoor and hypogeal environments), and intrinsic metric inaccuracy, which necessitates integration with a reliable metric dataset, such as that provided by SLAM surveying.

In conclusion, the integration of RBM and IBM through low-cost equipment is therefore proposed as a balanced solution in terms of quality, time, and cost. Individually, the two technologies present specific limitations; integrated within a single workflow, they combine geometric precision, graphic detail, and economic sustainability, responding to contemporary needs for knowledge and conservation of architectural heritage.

The substantial volume of data engendered by RBM and IBM acquisitions necessitates a subsequent and articulated data-processing phase, aimed at optimising datasets through the implementation of cleaning and structuring processes on raw survey data. This step is of crucial methodological significance in ensuring the reliability and effectiveness of subsequent analyses. In this context, a significant number of software tools, grounded in open-source logics, facilitate research in the development of replicable and interoperable methodologies and workflows. Furthermore, the open-source paradigm offers the possibility to adapt and customise processing algorithms to meet specific needs and targeted research objectives.

CloudCompare v.2.6.1 [25] and MeshLab v.2025.07 [26] are two open-source software programs that are both highly established and widely utilised. Despite exhibiting divergent operational characteristics, both software programs furnish a suite of sophisticated tools for the processing of point clouds and meshes, respectively. In addition to these solutions, there are other freely distributed software packages, such as RealityScan 2.1 [27], which integrate into operational workflows with a view to strengthening the replicability and methodological consistency of the proposed approaches.

The final output of data processing is a clean, structured, lightweight, and accessible dataset, a prerequisite for the subsequent Data Extraction phase. This stage enables extraction of the informational values contained within complex 3D datasets, translating geometric and radiometric complexity into formats suitable for the interpretation, analysis and management of built heritage [28,29].

Through segmentation and semantic enrichment, survey outputs are structured into interoperable information systems, transcending descriptive representation of raw data [30]. In this context, data extraction represents the transition from survey to knowledge, orienting digital models towards interpretation and management processes [31].

3. Results

3.1. Historical Knowledge

The management of water resources has historically constituted a fundamental prerequisite for the establishment and continuity of human settlements, particularly within environmentally constrained contexts [14]. In Matera, characterised by alternating periods of intense rainfall and prolonged drought, the development of the historical urban fabric is intrinsically linked to the implementation of complex and sustainable water systems [14,32,33]. Situated at approximately 400 m above sea level, between the Matera Hills and the Apulian MurgePlateau, the *Sassi* of Matera urban districts represent an exemplary case of long-term human adaptation, where infrastructures for water capture, conveyance, sedimentation, storage, and reuse were progressively integrated into the built environment [34].

The excavation of hypogean dwellings within the calcarenitic slopes facilitated both habitation and the implementation of a water harvesting system [32]. This integrated system operated at multiple scales: private cisterns, typically located within or adjacent to dwellings, collected rainwater for domestic and livestock use, while potable water was supplied through public fountains fed by groundwater captured via wells in the upper parts of the city [32,35]. The resulting urban configuration reflects a sophisticated balance between natural morphology and anthropogenic intervention, wherein the typology and

distribution of hydraulic infrastructure were directly conditioned by the geomorphological context [36].

However, demographic growth during the sixteenth century led to the progressive conversion and occlusion of numerous private cisterns into residential spaces, thereby compromising the equilibrium of the water system and necessitating the construction of large public storage infrastructures, known as *palombari* [32,35,37].

Among these, the construction of the *Palombaro Purgatorio Vecchio* in 1844 under Archbishop Antonio di Macco (Figure 3a) demonstrated a continued adaptive response to increasing water demand. This large cistern, with a capacity of approximately 1.5 million litres, functioned as a terminal reservoir for potable water conveyed from the surrounding hills, embodying both technical innovation and the reuse of pre-existing hypogean structures [34]. Even after the integration of Matera into the Apulian Aqueduct network in 1927, such infrastructures retained a strategic role in ensuring water supply continuity during periods of service interruption, as documented by archival records [34] (Figure 3b).

3.2. Hydromorphic Knowledge

The territory of Matera is characterised by a marked morphological and geological heterogeneity, configuring itself as a transitional “hinge” between two distinct landscape systems: the western hills—*Cimitero*, *Macamarda*, *Serra Venerdì*, and *Lapillo*, belonging to the *Avanfossa Bradanica*, and the karst environment of the *Gravina Stream* [37] (Figure 4). This duality has exerted a decisive influence on landscape configuration, settlement patterns, and the historical strategies developed for water resource management [38–40].

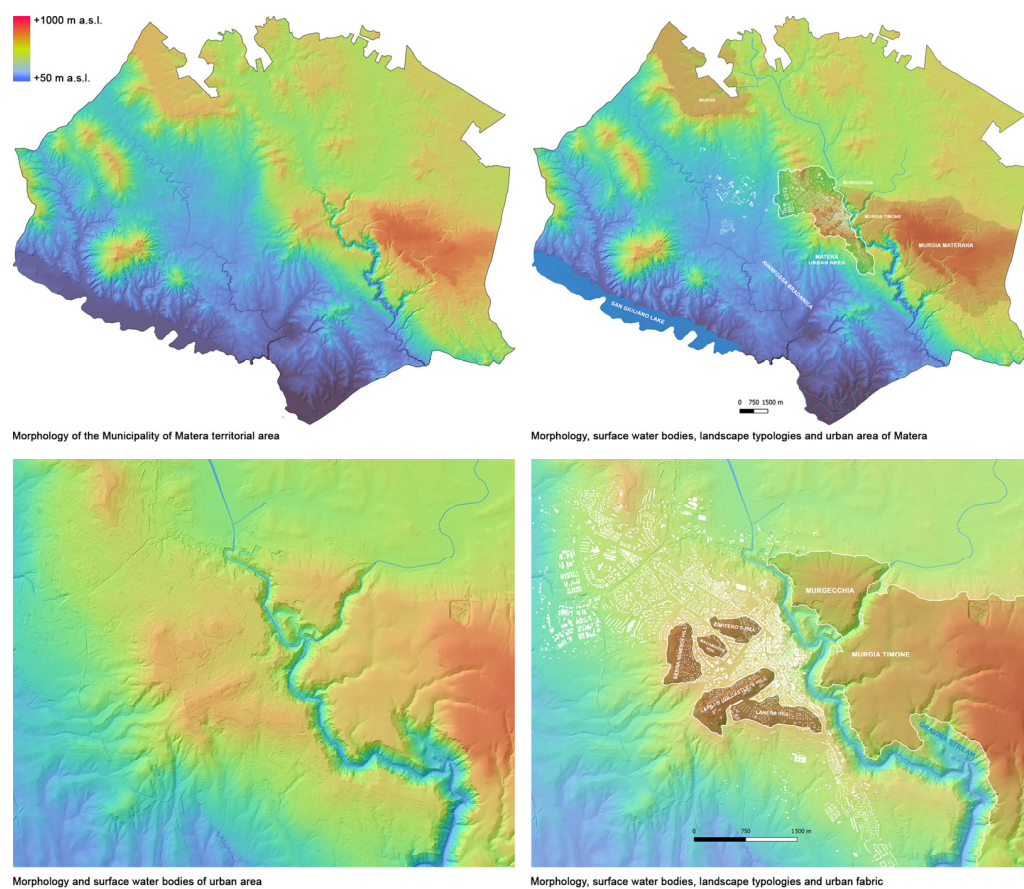

Figure 4. Morphological and landscape characteristics of the urban area of Matera.

Matera is located along the south-western margin of the Apulian Carbonate Platform and is characterised by a Plio-Pleistocene sedimentary cover of calcarenites, sands, and

clays [39,41]. In the *Sassi*, the presence of permeable calcarenite (commonly referred to by labourers in the construction sector as *tufo*) facilitated excavation and the development of hypogean and hydraulic systems while limiting the formation of continuous aquifers and resulting in fragmented water resources [38,39]. The geomorphology is dominated by the *Gravina* of Matera, an erosional incision acting as an episodic drainage system, which has strongly influenced the settlement's spatial organisation [38,39,41]. In a context of limited rainfall, the lack of natural water availability led to the implementation of complex systems for the collection and storage of meteoric and spring waters, transforming environmental constraints into engineered hydraulic solutions, such as rock-cut cisterns [33,42].

In this system, the western hills (Figure 4), despite their apparent aridity, played a fundamental hydrological role. Due to their topographic position, they functioned as primary interception zones for meteoric and spring waters, particularly where sandy and clayey layers intersect, as observed near *Castello Tramontano* (the Renaissance castle of the city). Through a network of channels and subterranean conduits equipped with settling basins, these waters were conveyed towards the historical urban fabric, where they were distributed to public fountains and stored in both public (*palombari*) and private cisterns, before ultimately discharging into the *Gravina* gorge [33,36,43].

The apparent unity of the urban fabric conceals a more complex territorial articulation, as evidenced by the existence of two distinct hydrographic watersheds corresponding to the *Sasso Barisano* and the *Sasso Caveoso* [43] (Figure 5).

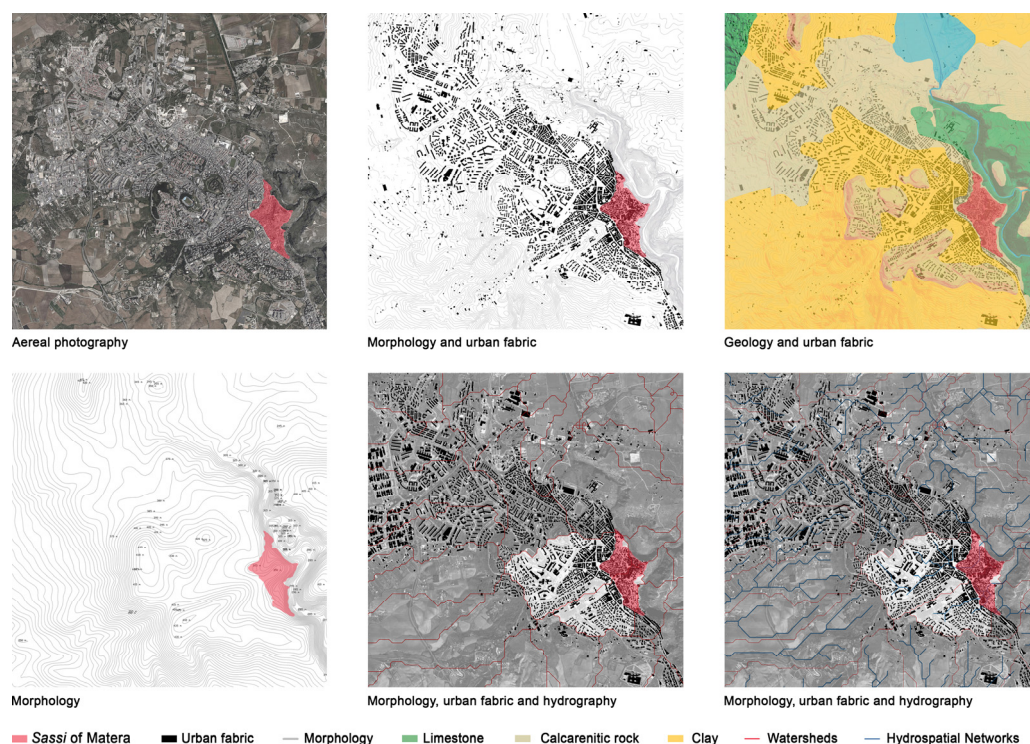

Figure 5. Schematic synthesis of the relationships between morphology, geology and hydrography in the territory of Matera.

The *Sasso Barisano* watershed, with an area of approximately 1.21 km², collects runoff from the *Macamarda* and *Lapillo* hills and channels it along *via Fiorentini*, its principal drainage axis, towards the *Gravina*, with an average slope of 7%. Conversely, the *Sasso Caveoso* watershed, extending over 0.66 km², develops from *via Castello* to *Piazza San Pietro Caveoso*, with its main drainage axis along *via Bruno Buozzi* and an average slope of 12% [43].

The analysis of these watersheds, supported by both contemporary data and historical cartography, reveals how settlement organisation was closely aligned with hydrological

dynamics, demonstrating a conscious and structured approach to water management (Figure 6).

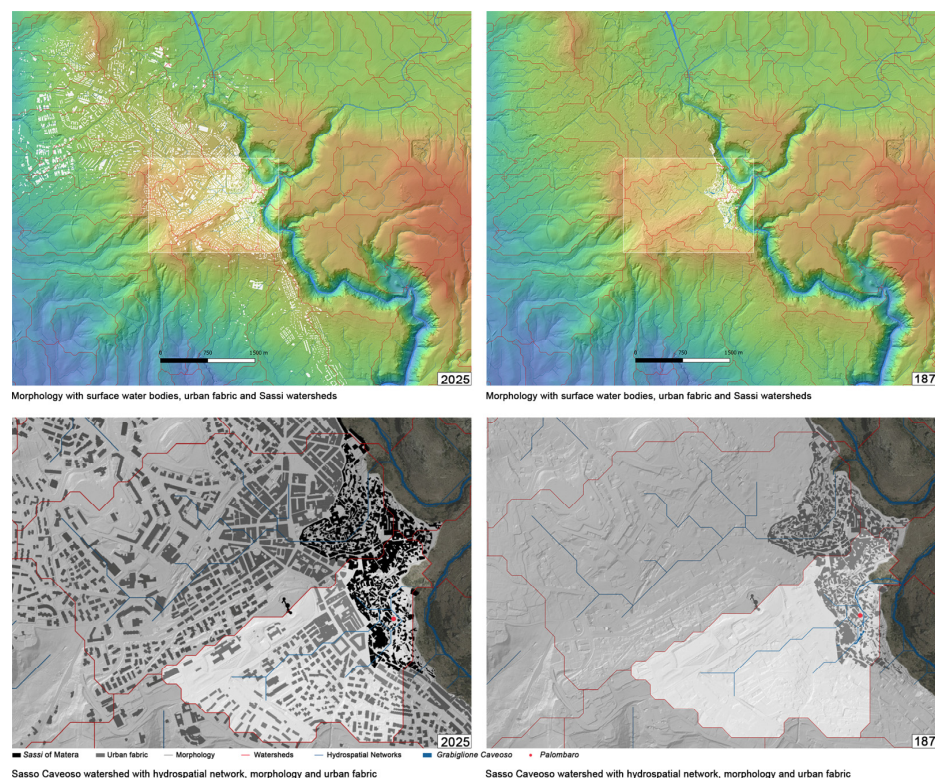

Figure 6. Comparative analysis of the current morphological and hydrographic setting of the *Sasso Caveoso* urban watershed and the historical settlement configuration in 1875.

In this perspective, the urban configuration of the *Sassi* emerges as the outcome of an intentional planning process, aimed at integrating systems of water collection, conveyance, and storage within a challenging environmental context. The surrounding hills, despite their limited permeability, were strategically incorporated into a hierarchical hydraulic system, serving as key zones for water interception. The localisation of major underground reservoirs, such as the *palombari*, was therefore strongly conditioned by the morphological and hydrological characteristics of the respective watersheds, as exemplified by the *Palombaro Purgatorio Vecchio* [33,43].

3.3. Geometric Knowledge

The operational steps undertaken to achieve the geometric knowledge of the case study are summarised in the workflow shown in Figure 2, which schematically outlines the adopted methodological sequence. Following a meticulously devised acquisition campaign, the survey was conducted through a dual, integrated approach combining RBM and IBM. A hybrid system was specifically implemented, involving the use of a mobile sensor equipped with SLAM technology, the BLK2GO (Leica Geosystems S.p.A., Cornegliano Laudense, Italy), for the rapid and continuous acquisition of a point cloud. This was complemented by IBM techniques based on the use of a smartphone camera (iPhone 16 Pro) aimed at radiometric integration and supporting subsequent reconstruction and texturisation processes.

Based on GrandSLAM technology, the BLK2GO is able to combine visual SLAM, LiDAR SLAM, and an inertial measurement unit (IMU), ensuring an accuracy of ± 10 mm in indoor environments, with an acquisition rate of 420,000 points/second and an operational range spanning from 0.5 m and 25 m [44]. The entire *Palombaro* complex was captured

through two scans: one of the *Palombaro* itself and one of the rooms above it. The most significant data from the survey are reported below: 21 min of acquisition; 145 way-points on 275 m of acquisition trajectory.

The acquired point cloud was initially processed using Leica Geosystems' proprietary software Cyclone Register 360 [45]. This approach enabled the alignment of the scanned datasets with an overall error of 0.003 m and an alignment robustness of 82%. The resultant dataset comprised a point cloud of 214,976,556 points, exported in.e57 format for subsequent data-processing stages (Figure 7).

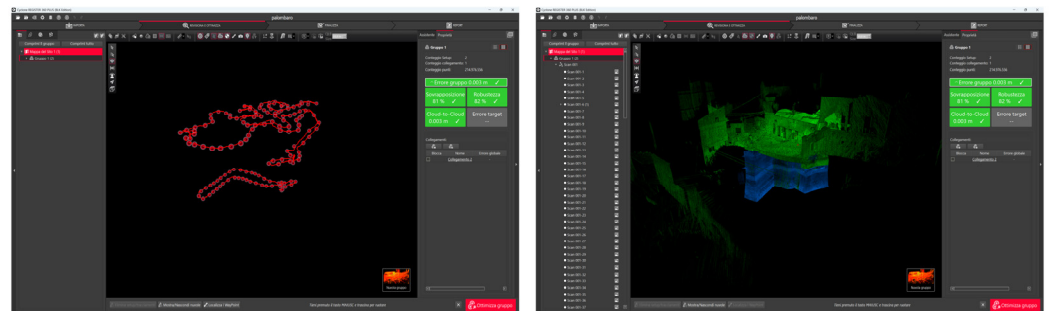

Figure 7. SLAM trajectory and scan waypoints on the left, and the two aligned point clouds on the right.

The subsequent data-optimisation step was carried out with the open-source software CloudCompare (v.2.6.1) [25], which facilitated the enhancement of data quality by the removal of noise and anomalies from the point cloud. The cleaning step was implemented using two algorithms: SOR filtering (Statistical Outlier Removal) and noise filtering. Subsequent to the cleaning process, a spatial subsampling step was conducted utilising the spatial model, with a minimum spacing of 0.01 m, to homogenise point density and optimise the information volume, thereby reducing the overall weight of the dataset.

The final result of this process was a point cloud comprising 14,894,425 points, which provides a robust foundation from geometric and dimensional perspectives, thereby establishing the foundation for subsequent steps of Data Extraction and analysis.

In order to address the limitations related to the radiometric output of RBM acquisition, a complete photogrammetric modelling process based on Structure from Motion (SfM) was employed using an iPhone 16 Pro smartphone as the sole acquisition tool. The workflow was designed to be low-cost, fast, and easily replicable while maintaining methodological rigor for applications in architectural surveying and built heritage documentation. The survey comprised on-site Data Capture and Data Processing.

Image acquisition was performed using an iPhone 16 Pro smartphone camera configured to ensure consistent, non-enhanced documentation. Settings included 24 mm (full-frame equivalent) wide-angle with no zoom, JPEG format (5712 × 4284 px), autofocus enabled, flash disabled, and filters/automatic post-processing disabled. The lens aperture was f/1.8, while exposure parameters were adjusted as required by on-site lighting conditions.

Photographs were captured on site following continuous parallel and oblique strips relative to the surfaces, maintaining an approximate 70–80% overlap both vertically and horizontally. Images were acquired primarily by moving along the perimeter of the structure, with variable camera height where feasible to support volumetric reconstruction. Additional coverage was dedicated to geometric discontinuities (e.g., edges, openings, and section changes), which are critical areas for Structure-from-Motion (SfM) processing. A total of 549 images were collected.

The dataset was imported into Reality Scan 2.1 for photogrammetric processing. Images underwent a preliminary quality check (sharpness, exposure, and coverage continuity), followed by automatic alignment and generation of a sparse point cloud (1,095,703 points)

and a dense point cloud (99,979,999 points). The resulting model was aligned and scaled using metric references derived from the SLAM survey, then converted into a mesh consisting of 83,981,195 polygons and 42,095,447 vertices, with subsequent texture generation. Finally, orthophotos were exported for downstream analysis.

Starting from these high-resolution models, it became feasible to extract floor plans (Figure 8), sections (Figure 9), and detailed orthometric views (Figure 10).

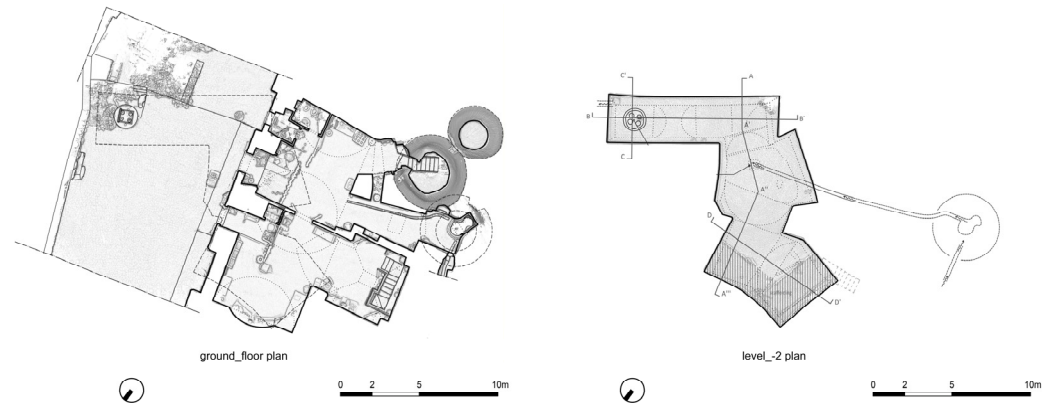

Figure 8. Floor plans for the ground floor and level-2 of the complex.



Figure 9. Significant sections of the *Palombaro*.

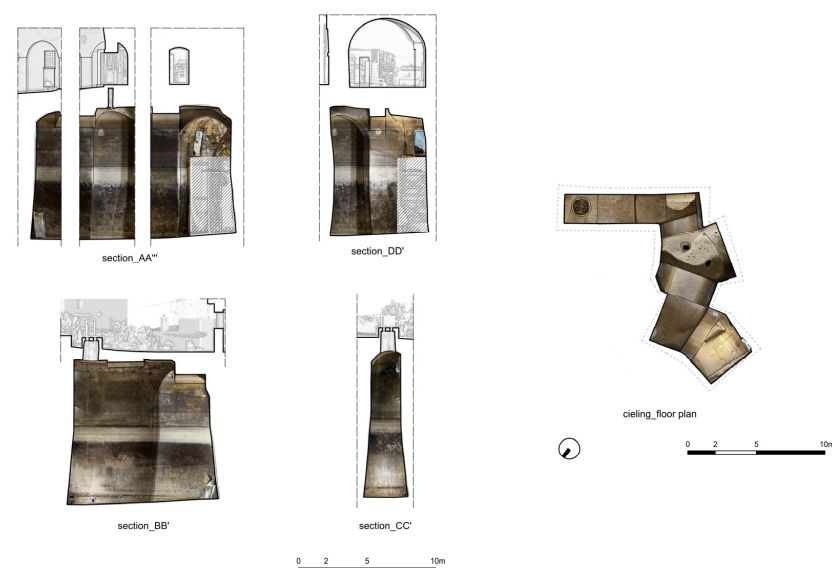

Figure 10. Detailed orthometric views.

The subsequent step of the analysis of materials, construction techniques, and specific functions of the water systems were facilitated as a result.

3.4. Materials and Construction Techniques Knowledge

The constructive and material understanding of the *Palombaro Purgatorio Vecchio* was significantly facilitated by the high-resolution Digital Survey carried out in the previous step and by the metric and orthometric outputs derived from it. This enabled a systematic reading of the spatial configurations and technical solutions of the underground infrastructure, providing an indispensable knowledge base for interpreting the construction techniques and materials employed.

This direct reading was integrated with a critical review of the specialist literature on the construction practices of the *Sassi* of Matera, allowing the observed material and constructive evidence to be placed within a consolidated historical–technical framework. The integration of geometric data, direct observation and historical sources thus made it possible to achieve an in-depth understanding of the technical logics that guided the construction of the *Palombaro*.

In the absence of the possibility of carrying out invasive sampling or direct stratigraphic soundings on the structure, the construction analysis was based on a morphological, geometric, and material reading of the accessible surfaces, formulating a hypothesis regarding the traditional practices and techniques adopted.

The *Palombaro* can be understood as a complex semi-hypogeal architecture, predominantly created through the subtraction of material within the calcarenite bedrock while also incorporating spaces formed through additive construction processes (Figure 11).

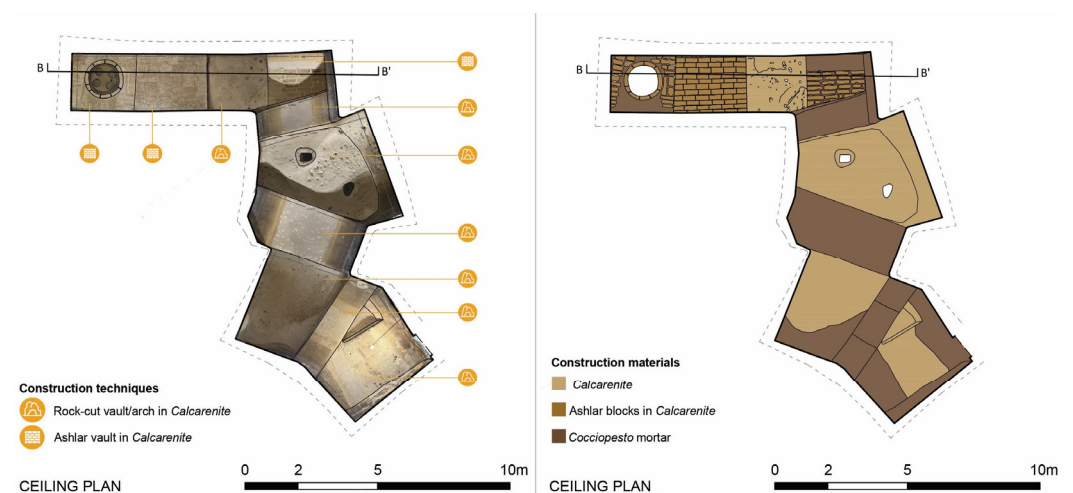

Figure 11. Materials and construction techniques of the vaulted system.

The material analysis (Figure 11) made it possible to clearly distinguish areas coated with *cocciopesto*-based mortars from those lacking such a coating. The localised absence of *cocciopesto* allowed for the identification, on the excavated surfaces, of traces of manual workmanship attributable to the use of traditional excavation tools such as the pickaxe [46], as well as three vaults constructed with squared calcarenite blocks arranged according to the traditional local masonry bonding commonly found in Materan dwellings (*lamioni*).

With regard to the constructed vaults, the central one is configured as a barrel vault (*a botte*), while the two lateral ones take the form of ramped barrel vaults. The eastern vault covers the last chamber of the *Palombaro* and incorporates the water-drawing opening built with calcarenite blocks, now covered by a perforated reinforced-concrete slab (Figure 11). In addition, three arched structural support elements formed through excavation are present.

The detailed analysis (Figure 12), corresponding to construction section B–B', makes it possible to understand the geometry of the vaults, the masonry bonding, the section of the opening, and the dimensions of the calcarenite blocks. The observation of the section

(Figure 12) shows that the springing levels of the constructed vaults were formed by three courses of calcarenite blocks set on piers obtained directly by cutting into the rock mass; in the other cases, the piers were entirely formed through material subtraction. The vaulted system as a whole also constitutes the structural support for the overlying walkway along *via Purgatorio Vecchio*.

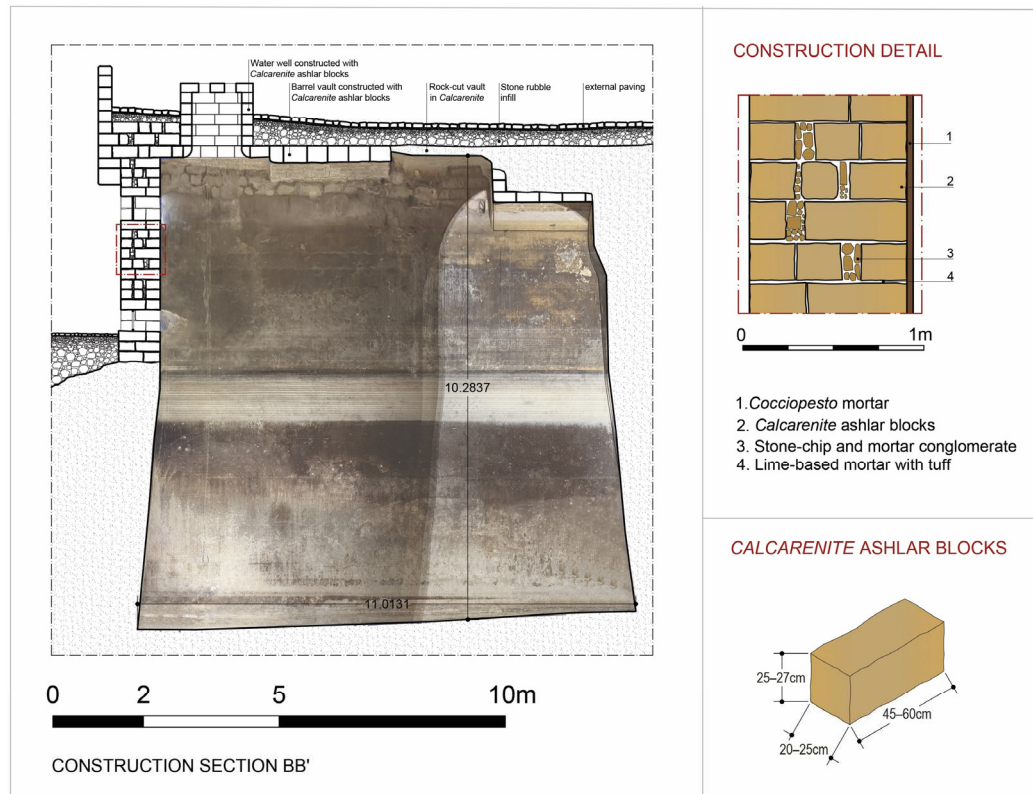

Figure 12. Construction section B–B’.

The closing wall on the eastern side, where the two overflow openings are located and through which water is discharged toward the *Grabiglione*, corresponding to present-day *via Bruno Buozzi*, has an overall thickness of approximately 90 cm, likely required to counteract internal hydrostatic pressure.

Based on the analysis of the graphic outputs and comparison with the specialist literature [47], this wall can be interpreted as a multi-leaf masonry constructed with calcarenite blocks and found directly on the rock substrate. Accordingly, the dimensions of the blocks, consistent with those documented for *Sassi* architecture, are approximately 25–27 cm in height, 20–25 cm in width, and 45–60 cm in length [47]. Observation of both faces of the wall revealed an alternation between blocks laid as stretchers and blocks laid as headers, the so-called *diatoni*, identifiable on the facing by dimensions close to 20 × 25/27 cm, while the stretcher blocks exhibited greater lengths.

The wall section is composed of spaced blocks achieving the overall thickness by means of an internal infill made of stone chips and mortar poor in lime or earth. In this configuration, the header blocks ensure transverse connection between the outer faces, contributing to the monolithic behaviour of the masonry, despite having a length shorter than the total wall thickness [47].

The analysis of the waterproof coating system was based on observation of a sample collected in situ (Figure 13). Sampling was limited exclusively to a very small portion of coating already in a state of deterioration and detachment from the substrate, in compliance with conservation requirements.



Figure 13. *Cocciopesto* mortar sample.

By analogy, the analysed sample can be attributed to a *cocciopesto*-type coating, a material traditionally used for waterproofing historic cisterns, as extensively documented in the Materan context and, in particular, in the *Palombaro Lungo*. Comparison with the stratigraphic description proposed for the *Palombaro Lungo* [12], however, highlights significant differences in the overall thickness of the coating, suggesting the existence of different construction practices for cisterns in Matera or subsequent maintenance interventions.

In the absence of extensive stratigraphic investigations and direct sections across the full development of the coating, the proposed interpretation therefore remains comparative in nature, grounded in the detailed analysis of the available sample.

In order to systematically investigate the nature of the coating and verify the proposed hypothesis, future laboratory analyses are planned to examine the sequence of coating layers, the chemical, granulometric, and mineralogical composition of the mortar, as well as the binder–aggregate ratio. These investigations will be conducted through observations using optical microscopy and scanning electron microscopy (SEM), with the aim of precisely characterising the *cocciopesto* and identifying the possible presence of salts responsible for coating disintegration and detachment phenomena.

The expected results will allow for refinement of the reconstruction of the waterproofing system of the *Palombaro Purgatorio Vecchio* and its inclusion within a broader comparative framework concerning waterproofing techniques in historic water infrastructures of the *Sassi* of Matera.

3.5. Integrated Knowledge

The systematisation of the outputs derived from the different steps enabled a transversal and multi-layered reading of the study area, making explicit the structural and functional relationships between the built fabric, the street network, and the infrastructures dedicated to water resource management. The critical integration of historical documentary source analysis, direct surveys, analyses of materials and historical construction techniques, and territorial analyses made it possible not only to identify the individual components of the system, but above all to reconstruct its overall articulation and modes of operation, thus

restituting the image of an integrated hydraulic organism, intrinsically connected to the site's morphology and to the historic urban layout (Figure 14).

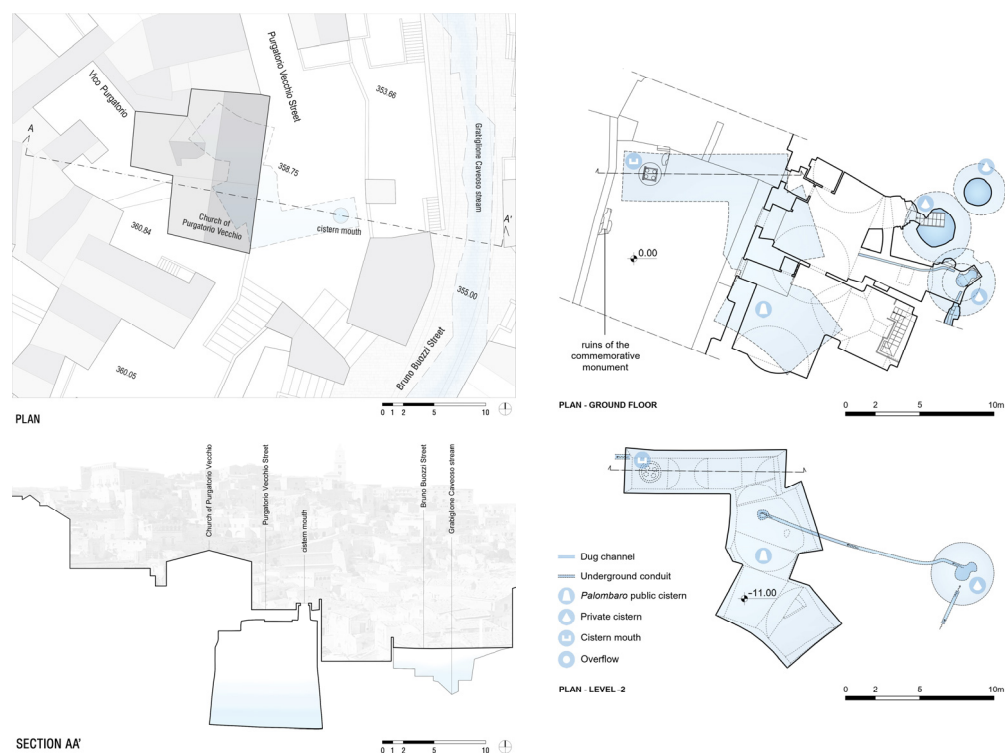

Figure 14. Technical drawings and analysis of the historical water systems.

The analytical technical drawings (Figure 14) allowed for an integrated interpretation of the water system in both plan and section, clarifying the altimetric arrangement, constructive geometry, and specific function of each element. This representation highlights how the hydraulic system cannot be interpreted as a mere assemblage of ancillary devices, but rather as a foundational infrastructure of the settlement, expressing advanced technical knowledge and a profound understanding of the geological, hydrological, and topographical characteristics of the territory.

The close relationship between architecture, ground, and water reveals a conscious design approach aimed at maximising water collection, regulating flows, and ensuring long-term hydraulic safety. Within this articulated system, several functional elements have been identified, hierarchically and functionally interconnected:

- The *Palombaro*, configured as the principal public water storage reservoir (Figure 15a), represents the core of the entire system. Its dimensions and underground location attest to its strategic role in collective water supply, plausibly linked both to the needs of the local community and to the central role of the Church of *Purgatorio Vecchio* within the urban context (Figure 15a);
- The water conveyance system, consisting of an underground conduit designed to channel and convey potable water towards the private cisterns (Figure 15b), constitutes an element of particular interest from a constructional perspective. The infrastructure presents, on its eastern side, a path directly excavated into the bedrock, while on the western side, it is defined by a masonry structure built of squared calcarenite blocks, revealing a mixed technical solution that combines excavation and masonry construction in response to local geological conditions;

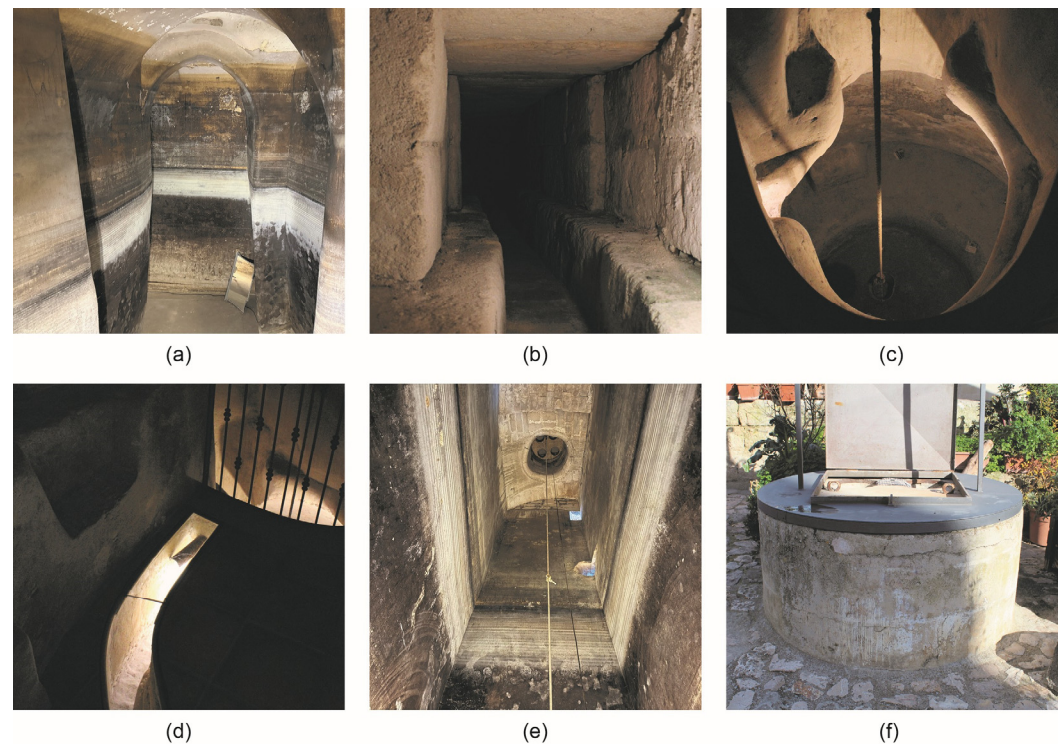

Figure 15. Photography of the historical water systems: (a) *Palombaro*; (b) underground conduit; (c) private cistern; (d) dug channel; (e) the two overflow systems; (f) cistern mouth.

- Three private cisterns, directly connected to the surrounding buildings (Figure 15c), testify to a widespread and integrated management of water, in which domestic and public dimensions coexist within the same infrastructural system. These devices were most likely pre-existing to the construction of the *Palombaro*, suggesting a gradual consolidation of the hydraulic system through the integration of earlier, smaller-scale facilities;
- A dug channel, exploiting the natural slope of the rock upon which the architectural complex is founded, enables the transfer of water from the private cisterns to the *Palombaro* (Figure 15d). This device confirms the adoption of a gravity-driven flow system, which is energetically efficient and fully integrated with the site's orography;
- The two distinct overflow systems of the *Palombaro*, probably constructed in different chronological steps (Figure 15e), play a fundamental role in regulating water levels and ensuring the hydraulic safety of the entire system. The overflow located at the higher elevation can be attributed to the original configuration, as it allowed for the accumulation of the maximum possible volume of water within the *Palombaro*. The second overflow system, positioned at a lower elevation near Via Bruno Buozzi, appears instead to respond to the need to reduce the water level inside the cistern, likely in relation to changing patterns of use, structural concerns, or new hygienic and sanitary requirements. Both overflow systems ultimately conveyed excess water into the *Grabiglione Caveoso*, underscoring how water management was conceived in close continuity with the natural dynamics of the territory. This direct relationship between artificial infrastructure and natural watercourse confirms the existence of a systemic approach to water management, in which the control of water does not imply its separation from the environmental context, but rather its conscious regulation within a balanced interaction between nature and the built environment;
- The cistern mouth, functioning as an access, inspection, and control element (Figure 15f), is clearly recognisable within the urban space and was constructed using

squared calcarenite blocks. Its visibility and constructional quality suggest not only a technical function, but also a symbolic and urban value, acting as a point of mediation between public space and underground infrastructure.

Through a typological and constructive analogy with the *Palombaro Lungo*, it is possible to hypothesise that the current configuration of the *Palombaro Purgatorio Vecchio* is the result of a process of aggregation and refunctionalisation of multiple pre-existing underground spaces, originally intended for residential use, productive activities (such as cellars), or small domestic cisterns. These spaces, progressively interconnected and enlarged, would have been incorporated into a unified system dedicated to the collection and management of water, according to an incremental logic typical of the evolutionary development of the rock-cut fabric of the *Sassi*.

In this sense, the *Palombaro Purgatorio Vecchio* represents a paradigmatic example of stratified architecture, in which excavation techniques and masonry construction coexist and integrate, resulting in a structure where form, material, and function are the outcome of a long-term adaptive process.

4. Discussions

The application of the methodology enabled a comprehensive interpretation of the investigated infrastructure, supporting its historical and functional reconstruction through the systematic integration of data derived from Indirect Knowledge and in situ surveys within Direct Knowledge. The results demonstrate that a framework originally developed for above-ground architectural heritage can be effectively extended to underground built heritage (UBH), provided that targeted adaptations are introduced, particularly in the early steps of the knowledge process, where the specific conditions of hypogeal environments significantly affect data acquisition and interpretative strategies [29,30,48–50].

Within the Indirect Knowledge step, territorial analysis emerges as a fundamental component. The geomorphological and hydrological characterisation of the context is essential for understanding materials and construction techniques, as well as the natural processes that have influenced urban transformations and enabled excavation practices. However, integrating data from the Systematic Literature Review with territorial and urban analyses may reveal inconsistencies, necessitating explicit cross-validation procedures to ensure the reliability and coherence of the knowledge framework.

In the Direct Knowledge step, methodological refinements are required due to the intrinsic complexity of UBH, characterised by irregular geometries, absence of conventional architectural references (such as verticality and orthogonality), and challenging environmental conditions, including limited lighting, high humidity, and restricted accessibility. These factors affect all stages of data acquisition, processing, and interpretation, requiring calibrated instrumentation and structured workflows capable of managing heterogeneous and incomplete datasets [1,2].

A comparison with Scan-to-BIM and HBIM workflows highlights both continuity and limitations. While these approaches—based on the integration of TLS and photogrammetry, semantic modelling, and, increasingly, automated classification and Machine Learning techniques—have proven effective for architectural heritage [29,30,48], and have evolved towards complex information systems for conservation and management [49,50], they are primarily suited to regular geometries and well-defined architectural elements. Their application to hypogeal environments remains problematic due to irregular morphologies, lack of architectural semantics, and difficult survey conditions, thus revealing a significant methodological gap.

Conversely, survey methodologies developed for caves and underground environments have consolidated multi-sensor approaches combining TLS and photogrammetry,

demonstrating their effectiveness in capturing complex geometries and high-resolution data [1,2]. However, these approaches are often focused on geometric documentation at the site scale. The methodology proposed in this study builds upon these contributions by explicitly structuring Integrated Knowledge as a central component and incorporating a systematic analysis of territorial and urban contexts, typically marginal in geomorphological or speleological studies.

The increasing adoption of SLAM-based mobile mapping systems further expands the methodological framework, enabling rapid and flexible data acquisition in complex and constrained environments. Although these systems generally provide lower accuracy compared to static laser scanning, they allow for the efficient generation of dense point clouds and demonstrate clear operational advantages in underground contexts [3–6,51]. Their integration with photogrammetric models constitutes an effective strategy, combining rapid acquisition with high-resolution geometric and material information.

Regarding metric restitution, the generation of orthophotos, plans, and sections remains a fundamental step in heritage documentation, with SfM-based photogrammetry proving particularly effective. However, in underground environments, irregular geometries and the absence of reference planes complicate these processes, requiring flexible projection strategies and adaptive workflows. The proposed methodology addresses these challenges through the integration of multi-source datasets and tailored procedures for metric extraction.

A further key aspect is the replicability and accessibility of the methodology, which incorporates low-cost and non-expert-friendly photogrammetric solutions, thereby facilitating its application in diverse contexts and promoting a more inclusive approach to heritage documentation [52]. Interdisciplinarity constitutes a core principle, enabling the integration of architectural, geomorphological, and territorial analyses across multiple scales, from the territorial dimension to architectural and morphological detail.

The principal contribution of the study lies in the combined adoption of a multi-scale and interdisciplinary framework, the explicit structuring of Integrated Knowledge, and the emphasis on methodological replicability through accessible tools. In particular, the formalisation of the integration step represents a distinctive element, conceived not merely as a technical operation but as a critical interpretative process in which heterogeneous data are validated, correlated, and synthesised within a coherent knowledge system, thereby contributing to bridging a significant methodological gap in both architectural heritage documentation and the study of underground environments.

5. Conclusions

The present study demonstrates that the UBH of Matera, and in particular the *Palombaro Purgatorio Vecchio*, is not a marginal element but a structuring component of a resilient urban system, deeply rooted in the geomorphological, hydrological, and cultural characteristics of the territory. Through the adoption of an interdisciplinary, multi-scale, and replicable methodological framework, the research enabled the reconstruction of the historical, spatial, material, and functional complexity of a major underground water infrastructure, restoring its role within the broader system of water management that shaped the development of the *Sassi*.

The integration of Indirect Knowledge—derived from historical sources, territorial analyses, and hydro-morphological studies—with Direct Knowledge based on digital survey, geometric modelling, and material-constructive analysis proved essential to achieving a comprehensive understanding of the structure. The results confirm that this *Palombaro* can be interpreted as an integrated hydraulic system, coherently responding to site morphology,

lithology, water availability, and urban dynamics, and embodying adaptive strategies capable of transforming environmental constraints into spatial and technical opportunities.

From a methodological perspective, the study validates the transferability of approaches developed for above-ground architectural heritage to underground contexts, provided that appropriate adaptations are introduced. In particular, the centrality of territorial and hydrogeological analysis in the early steps of the knowledge process, together with the integration of complementary digital survey techniques—such as SLAM-based systems and image-based photogrammetry—emerged as fundamental for addressing the complexity of subterranean environments.

At the same time, the research highlights critical issues requiring further investigation, notably the integration and cross-validation of heterogeneous sources, ranging from historical documentation to GIS-based territorial models and high-resolution 3D datasets. Ensuring coherence across multiple scales and domains remains a key challenge, especially in the analysis of stratified underground structures subject to continuous transformation.

The results also suggest several directions for future development. A priority concerns the consolidation and progressive standardisation of the methodological workflow through the definition of shared protocols for Data Capture, Data Processing, and Data Extraction, specifically calibrated for UBH, in order to ensure comparability among case studies and support interoperable digital archives. Furthermore, extending the approach to other underground hydraulic systems would enable comparative analyses, contributing to the identification of recurring typologies, shared construction logics, and adaptive strategies, and supporting the definition of a taxonomy of historic underground water systems.

At the same time, the research underlines the potential for enhancing accessibility and cultural valorisation through digital tools, virtual environments, and educational applications capable of making otherwise inaccessible spaces available to a broader public, thereby fostering awareness of the infrastructural dimension of cultural heritage.

Finally, the study highlights the relevance of historic underground water systems for contemporary debates on sustainable water management. Principles such as distributed collection, runoff control, and integration with natural processes—intrinsic to these infrastructures—represent resilient models that can inform current environmental strategies.

Author Contributions: These authors contributed equally to this work. All authors have read and agreed to the published version of the manuscript.

Funding: This research was funded by the European Union—Next Generation EU, Mission 4, Component 1 (CUP C43C22000400006), under the National Recovery and Resilience Plan (NRRP)—“Tech4You Project”, assigned to the University of Basilicata, Spoke 4 (PP4.2.1—Materials, Architecture and Design: Open Knowledge and Innovative Digital Tools for Cultural Heritage; Scientific Coordinator: Antonella Guida).

Data Availability Statement: Data is contained within the article.

Conflicts of Interest: The authors declare no conflicts of interest.

References

1. González-Aguilera, D.; Muñoz-Nieto, Á.; Gómez-Lahoz, J.; Herrero-Pascual, J.; Gutiérrez-Alonso, G. 3D Digital Surveying and Modelling of Cave Geometry: Application to Paleolithic Rock Art. *Sensors* **2009**, *9*, 1108–1127. [[CrossRef](#)]
2. Grussenmeyer, P.; Burens, A.; Landes, T.; Carozza, L.; Mathé, V. 3D Multi-scale Scanning of the Archaeological Cave “Les Fraux” in Dordogne (France). In *Proceedings of the 4th International Conference, EuroMed 2012, Lemessos, Cyprus, 29 October–3 November 2012*; Springer: Berlin/Heidelberg, Germany, 2021. [[CrossRef](#)]
3. Pepe, M.; Alfio, V.S.; Costantino, D.; Herban, S. Rapid and Accurate Production of 3D Point Cloud via Latest-Generation Sensors in the Field of Cultural Heritage: A Comparison between SLAM and Spherical Videogrammetry. *Heritage* **2022**, *5*, 1910–1928. [[CrossRef](#)]

4. Farella, E.M. 3D Mapping of Underground Environments with a Hand-Held Laser Scanner. *Boll. Soc. Ital. Fotogram. E Topogr.* **2016**, *2*, 1–10.
5. Štroner, M.; Urban, R.; Křemen, T.; Braun, J.; Michal, O.; Jiříkovský, T. Scanning the underground: Comparison of the accuracies of SLAM and static laser scanners in a mine tunnel. *Measurement* **2025**, *242*, 115875. [CrossRef]
6. Di Stefano, F.; Chiappini, S.; Gorreja, A.; Balestra, M.; Pierdicca, R. Mobile 3D scan LiDAR: A literature review. *Int. J. Remote Sens.* **2021**, *12*, 2387–2429. [CrossRef]
7. Di Stefano, F.; Torresani, A.; Farella, E.M.; Pierdicca, R.; Menna, F.; Remondino, F. 3D Surveying of Underground Built Heritage: Opportunities and Challenges of Mobile Technologies. *Sustainability* **2021**, *13*, 13289. [CrossRef]
8. Zlot, R.; Bosse, M.; Greenop, K.; Jarzab, Z.; Juckes, E.; Roberts, J. Efficiently Capturing Large, Complex Cultural Heritage Sites with a Handheld Mobile 3D Laser Mapping System. *J. Cult. Herit.* **2014**, *15*, 670–678. [CrossRef]
9. Ch’ng, E.; Cai, S.; Zhang, T.E.; Leow, F.T. Crowdsourcing 3D cultural heritage: Best practice for mass photogrammetry. *J. Cult. Herit. Manag. Sustain. Dev.* **2019**, *9*, 24–42. [CrossRef]
10. Murtiyoso, A.; Grussenmeyer, P. Experiments Using Smartphone-Based Videogrammetry for Low-Cost Cultural Heritage Documentation. *Int. Arch. Photogramm. Remote Sens. Spat. Inf. Sci.* **2021**, *46*, 487–491. [CrossRef]
11. Musicco, A.; Rossi, N.; Verdoscia, C. Accuracy Evaluation of Smartphone-Based Videogrammetry for Cultural Heritage Documentation Process. *Int. Arch. Photogramm. Remote Sens. Spat. Inf. Sci.* **2023**, *48*, 1119–1126. [CrossRef]
12. Guida, A.; Mecca, I. The “Palombaro” (“Sassi” of Matera, Italy): The Interaction Between Water and Construction Materials. In Proceedings of the 9th International Conference on NDT of Art, Jerusalem Israel, 25–30 May 2008.
13. Masini, N.; Fiore, G. *Verso un Restauro Digitalmente Inteso*; Gangemi Editore: Roma, Italy, 2025; ISBN 9788849253948.
14. Altamura, D. Matera and Water: Systematic Literature Review and Guidelines for Future Scientific Research. In *Emerging Perspectives on the Built Environment—Results of the 1st International Conference of Dot.AT.i 2025 “Knowing and Connecting”*; Springer International Publishing: Cham, Switzerland, 2026.
15. RSDI Basilicata Open-Source Web Platform. Available online: <https://rsdi.regione.basilicata.it/> (accessed on 28 January 2026).
16. QGIS Software. Available online: <https://qgis.org/> (accessed on 24 February 2026).
17. GRASS GIS 7.2.0. Available online: https://grass.osgeo.org/news/2016_12_28_grass_gis_7_2_0_released/ (accessed on 24 February 2026).
18. Lindsay, J.B. Efficient Hybrid Breaching-Filling Sink Removal Methods for Flow Path Enforcement in Digital Elevation Models. *Hydrol. Process.* **2016**, *30*, 846–857. [CrossRef]
19. Tarboton, D.G.; Bras, R.L.; Rodriguez-Iturbe, I. On the Extraction of Channel Networks from Digital Elevation Data. *Hydrol. Process.* **1991**, *5*, 81–100. [CrossRef]
20. Orlandini, S.; Tarolli, P.; Moretti, G.; Dalla Fontana, G. On the Prediction of Channel Heads in a Complex Alpine Terrain Using Gridded Elevation Data. *Water Resour. Res.* **2011**, *47*, W02538. [CrossRef]
21. Akbar, A.Q.; Mitani, Y.; Nakanishi, R.; Djamaluddin, I.; Sugahara, T. Impact Assessment of Digital Elevation Model (DEM) Resolution on Drainage System Extraction and the Evaluation of Mass Movement Hazards in the Upper Catchment. *Geosciences* **2024**, *14*, 223. [CrossRef]
22. Porcari, V.D.; Priore, A.; Porcari, S.; Fattore, C. Feature Extraction of Point Clouds for Cultural Heritage Monitoring and Conservation. In *Envisioning the Futures—Designing and Building for People and the Environment, Proceedings of the Colloqui.AT.e 2025, Trento, Italy, 11–14 June 2025*; Albatici, R., Dalprà, M., Gatti, M.P., Maracchini, G., Torresin, S., Eds.; Springer Nature: Cham, Switzerland, 2025; pp. 524–541.
23. Verykokou, S.; Ioannidis, C. An Overview on Image-Based and Scanner-Based 3D Modeling Technologies. *Sensors* **2023**, *23*, 596. [CrossRef]
24. Remondino, F.; Campana, S. *3D Recording and Modelling in Archaeology and Cultural Heritage: Theory and Best Practices*; Archaeopress: Oxford, UK, 2014; ISBN 9781407312309.
25. CloudCompare—3D Point Cloud and Mesh Processing Software—OpenSource Project 2015. Available online: <https://www.cloudcompare.org/> (accessed on 24 February 2026).
26. Callieri, M. Meshlab as a Complete Open Tool for the Integration of Photos and Colour with High-Resolution 3D Geometry Data. In *CAA2012, Proceedings of the 40th Conference in Computer Applications and Quantitative Methods in Archaeology, Southampton, UK, 26–30 March 2012*; Meshlab Proprietary of Council National Research (CNR), Pisa, Italy; Pallas Publications: Dublin, Ireland, 2012; pp. 406–416.
27. Epic Games. *RealityScan 2.1*; Proprietary of “RealityScan 2.12”; Epic Games: Cary, NC, USA, 2025; Available online: <https://www.realityscan.com/en-US/news/realityscan-2-1-is-now-available> (accessed on 24 February 2026).
28. Brumana, R.; Della Torre, S.; Oreni, D.; Previtali, M.; Cantini, L.; Barazzetti, L.; Franchi, A.; Banfi, F. HBIM Challenge Among the Paradigm of Complexity, Tools and Preservation: The Basilica Di Collemaggio 8 Years After the Earthquake (L’Aquila). *Int. Arch. Photogramm. Remote Sens. Spat. Inf. Sci.* **2017**, *XLII-2/W5*, 97–104. [CrossRef]

29. Rodríguez-Moreno, C.; Reinoso-Gordo, J.F.; Rivas-Lpez, E.; Gmez-Blanco, A.; Ariza-Lpez, F.J.; Ariza-Lpez, I. From Point Cloud to BIM: An Integrated Workflow for Documentation, Research and Modelling of Architectural Heritage. *Surv. Rev.* **2018**, *50*, 212–231. [[CrossRef](#)]
30. Grilli, E.; Remondino, F. Classification of 3D Digital Heritage. *Remote Sens.* **2019**, *11*, 847. [[CrossRef](#)]
31. Boje, C.; Guerriero, A.; Kubicki, S.; Rezgui, Y. Towards a Semantic Construction Digital Twin: Directions for Future Research. *Autom. Constr.* **2020**, *114*, 103179. [[CrossRef](#)]
32. Laureano, P. *Giardini Di Pietra: I Sassi di Matera e la Civiltà Mediterranea*; Bollati Boringhieri: Turin, Italy, 1993; ISBN 8833908127.
33. Manfreda, S.; Mita, L.; Dal Sasso, S.F.; Dibernardi, F.; Ermini, R.; Mininni, M.; Bixio, A.; Conte, A.; Fiorentino, M. La Gestione Delle Risorse Idriche Nella Città dei Sassi (Matera) Water Resources Management in the City of Sassi (Matera). *L'Acqua* **2016**, *3*, 39–46.
34. Fonseca, C.D.; Demetrio, R.; Guadagno, G. *Matera*; Laterza: Bari, Italy, 1999; ISBN 9788842056706.
35. Padula, M.; Motta, C. *Piazza Vittorio Veneto: La Storia*; IEM: Matera, Italy, 1992.
36. Viti, E.; Lupo, T. *Appunti Di Matera Sotterranea 1. PALOMBARI*; Magister, S., Ed.; Edizioni Magister: Matera, Italy, 2020; ISBN 978-88-85564-28-2.
37. Rota, L. *Matera: Storia Di Una Città*; Edizioni Giannatelli: Matera, Italy, 2011; ISBN 9788897906001.
38. Beneduce, P.; Festa, V.; Francioso, R.; Schiattarella, M.; Tropeano, M. Conflicting Drainage Patterns in the Matera Horst Area, Southern Italy. *Phys. Chem. Earth Parts A/B/C* **2004**, *29*, 717–724. [[CrossRef](#)]
39. Bellanova, J.; Calamita, G.; Catapano, I.; Ciucci, A.; Cornacchia, C.; Gennarelli, G.; Giocoli, A.; Fisangher, F.; Ludeno, G.; Morelli, G.; et al. GPR and ERT Investigations in Urban Areas: The Case-Study of Matera (Southern Italy). *Remote Sens.* **2020**, *12*, 1879. [[CrossRef](#)]
40. Doglioni, A.; Simeone, V. Gravine: Peculiar Morphological Elements of the Landscape in Southern-East Italy. *Ital. J. Eng. Geol. Environ.* **2019**, 29–32. [[CrossRef](#)]
41. Festa, V.; Sabato, L.; Tropeano, M. 1:5000 Geological Map of the Upper Cretaceous Intraplatform-Basin Succession in the “Gravina Di Matera” Canyon (Apulia Carbonate Platform, Basilicata, Southern Italy). *Ital. J. Geosci.* **2018**, *137*, 3–15. [[CrossRef](#)]
42. Bobbink, I.; Gao, W.; Banfi, I. A Hidden Water-Harvesting System: The Sassi Di Matera. *Blue Pap.* **2023**, *2*, 168–177. [[CrossRef](#)]
43. Altamura, D.; Ermini, R. Multidisciplinary Analysis of Inaccessible Historical Water Infrastructures and Urban Transformations: The Case Study of the Grabiglioni in Matera, Italy. *Geographies* **2025**, *5*, 48. [[CrossRef](#)]
44. *LEICA GEOSYSTEMS—BLK2GO Technology*; Leica Geosystems AG: Heerbrugg, Switzerland; Available online: <https://shop.leica-geosystems.com/it/it-IT/leica-blk/blk2go/technology> (accessed on 14 December 2025).
45. *Leica Cyclone Register 360*; Leica Geosystems AG: Heerbrugg, Switzerland; Available online: <https://leica-geosystems.com/it-it/products/laser-scanners/software/leica-cyclone/leica-cyclone-register-360> (accessed on 28 January 2026).
46. Restucci, A. *Matera: I Sassi: Manuale Del Recupero*; Electa: Beira, Mozambique, 1998; ISBN 8843566040.
47. Giuffrè, A.; Carocci, C. *Codice di Pratica per la Sicurezza e la Conservazione Dei Sassi di Matera*; La, B., Ed.; Edizioni la Battuta: Matera, Italy, 1997; ISBN 108885425364.
48. Croce, V.; Caroti, G.; De Luca, L.; Jacquot, K.; Piemonte, A.; Véron, P. From the semantic point cloud to heritage-building information modeling: A semiautomatic approach exploiting machine learning. *Remote Sens.* **2021**, *13*, 461. [[CrossRef](#)]
49. Ávila, F.; Blanca-Hoyos, Á.; Puertas, E.; Gallego, R. HBIM: Background, Current Trends, and Future Prospects. *Appl. Sci.* **2024**, *14*, 11191. [[CrossRef](#)]
50. Parente, M.; Ottoni, F. HBIM and information management for knowledge and conservation of architectural heritage: A review. *Heritage* **2025**, *8*, 306. [[CrossRef](#)]
51. Barba, S.; Ferreyra, C.; Cotella, V.A.; Di Filippo, A.; Amalfitano, S. A SLAM integrated approach for digital heritage documentation. In *Culture and Computing. Interactive Cultural Heritage and Arts, Proceedings of the 9th International Conference, C&C 2021, Held as Part of the 23rd HCI International Conference, HCII 2021, Virtual Event, 24–29 July 2021*; Springer International Publishing: Cham, Switzerland, 2021. [[CrossRef](#)]
52. Rahaman, H.; Champion, E. To 3D or not 3D: Choosing a photogrammetry workflow for cultural heritage groups. *Heritage* **2019**, *2*, 1835–1851. [[CrossRef](#)]

Disclaimer/Publisher’s Note: The statements, opinions and data contained in all publications are solely those of the individual author(s) and contributor(s) and not of MDPI and/or the editor(s). MDPI and/or the editor(s) disclaim responsibility for any injury to people or property resulting from any ideas, methods, instructions or products referred to in the content.