

VISUALIZATION OF SUBMERGED ANNULAR JET EXITED BY MEANS OF A SYNTHETIC JET

Nino E., Di Tommaso R.M.

University of Basilicata
School of Engineering
Potenza ITALY
enrico.nino@unibas.it

ABSTRACT

In the school present paper the characterization of the flow field generated by means of a submerged gaseous jet exited by means of a coaxial synthetic jet has been investigated. The porpoise of this investigation is to infer the aerodynamic interaction of the two fluid structures that play an interesting role in several industrial applications like jet actuator, flame stability in the combustor for mini/micro gas turbine, etc.

Substantially two laser techniques have been employed: a Laser Döppler Velocimetry (LDV) featuring a high signal-noise ratio able to extract information from velocity time series in a few location in the jet flow and used, also, for an accurate determination of the *Reynolds* number. A Particle Image Velocimetry (PIV) system is also employed, in order to obtain instantaneous two dimensional velocity distribution overall the entire gaseous jet. Both techniques have been carried out by stretching the influences of coherent structures generated in the jet, by means of natural aerodynamic effect and by means of perturbation forced in the flow by means of the synthetic coaxial jet. The investigated conditions are ranging from Reynolds number (*Re*) 1000 to 3000 at several plate distance nozzle diameter ratio (but only the most significant results obtained at $h/d=2$ are reported in this paper). The synthetic jet has been generated by means of a loudspeaker driven at a pure sinusoidal wave at several frequencies in order to obtain different *Strouhal* number (*St*).

Keywords: Synthetic Jet; Annular Jet; Particle Image Velocymetry

INTRODUCTION

Enhancement of mixing between jets and surrounding fluids is important in many industrial applications. For examples, in gas burners, the mixing enhancement can improve thermal efficiency, emissions and combustion stability. Though the mixing in jets is inherently intense due to the high intensity of turbulence, in case of small size jets, the mixing is reduced due to the delayed development of turbulent shear layers at low Reynolds numbers.

Therefore, there is a great need for effective mixing devices for small-scale fluid equipments such as combustors in micro gas turbines. Annular jet is one of the most typical free shear layers encountered in the fluid dynamics with apparently very simple boundary conditions. The existence of inner

nozzle body, however, gives a profound complexity to the flow: a recirculating vortex region is formed just downstream the nozzle inner body and the annular jet column meets at the end of the recirculating region. A strong mixing occurs between the annular jet and the recirculating vortex region. It is also well known that the flow has many practical applications in the field of a combustion nozzle and spraying apparatus. In spite of importance in both fluid dynamical and practical applications, experimental investigations on the annular jets are very scarce. Ko & Chan [1]-[2] studied the flow comprehensively with hot wire anemometers, which has an inevitable ambiguity of flow reversal in the developing region of this flow, especially in the recirculating region. Durao & Whitelaw [3] applied LDV method; the exit shape of both annular nozzle has special

geometries in the sense that they have no straight annular portion parallel to jet axis.

In recent years, synthetic jet actuators were proposed and shown to be a useful tool for flow control, especially separation control [4]-[5], flow vectoring [6] and mixing enhancement [7]. A synthetic jet actuator known also as a zero net-mass-flux actuator causes an alternating flow out from and into a slot or an orifice. This alternating flow with high frequency can agitate the flow field and generate a mean jet flow named “a synthetic jet” in sense of being synthesized from the surrounding fluids.

The mixing of a circular jet with synthetic jet actuators was studied by Davis and Glezer [7]. They employed nine arc slots around a primary jet nozzle to agitate azimuthal instability of axisymmetric shear layers straight pipe. The synthetic jet actuator was constituted by a coaxial annular gap, an enclosed cavity and a piezoelectric actuator. An alternating flow through the gap was produced by the vibration of a piezoelectric actuator. Also Koso [8] studied the mixing of an annular jet coupled with an annular synthetic jet. The author applied an hot wire anemometer technique and a smoke visualization one. Travnicek and Tesar [9] individuated two different regime in an annular impacting jet acoustical excited and not, by means of the vibration of the membrane of a loudspeaker directly pointed out in the flow, at a $Re = 28600$ and several excitation frequency. The author characterized the obtained result by means of the *Strouhal* number (St). Fasanella et al. [10] studied the impinging jet on a flat surface at low Re with a sort of acoustical excitation of the jet by means of an external loudspeaker positioned over the plenum from which air was forced into the nozzle. They observed a significant increase of the local heat transfer distribution due to the jet instability generated by the acoustical perturbation. Vanierschot and Van den Bulck [11] studied, by means of a PIV technique, the merging zone of an annular swirled jet. Tesar and Travnicek [12] studied the effect of a synthetic jet on an annular gaseous jets with an approach quite similar at that adopted in this work, with the

difference of generate the synthetic jet directly in the plenum behind the annular discharge orifice. Also O'Connor et al. [13] studied an annular jet with induced perturbation. Vanierschot and Van den Bulck studied the precessing present in a turbulent annular jets and Danlos et al. [15] investigated a large section annular jet.

In the present study an annular impinging jet, formed by a nozzle forming a turbulent jet at relatively low Re and by a synthetic jet coaxial with the first, has been investigated. The interaction of the two jets, when the synthetic one is activated, generates a strong instability with repercussion along the jet axis and the impinged surface.

EXPERIMENTAL SET-UP

A PIV system has been employed to analyze the instantaneous behavior of the velocity field. The adopted system (whose layout is reported in Fig. 1) is based on two pulsed Nd:YAG lasers firing on the second harmonic (green 532 nm). The beams, properly separated in time, are recombined on the same optical path by a polarized dichroic filter. Then the beams are expanded in one direction, by combinations of spherical (negative) and cylindrical lens, to obtain a 100 mm wide and 0.3 mm thick laser sheet in the measuring region. The laser sheet is used to illuminate the airflow below the nozzle and over the plate. A fog generator has been used to disperse water droplets seeding in the feed duct to the test nozzle.

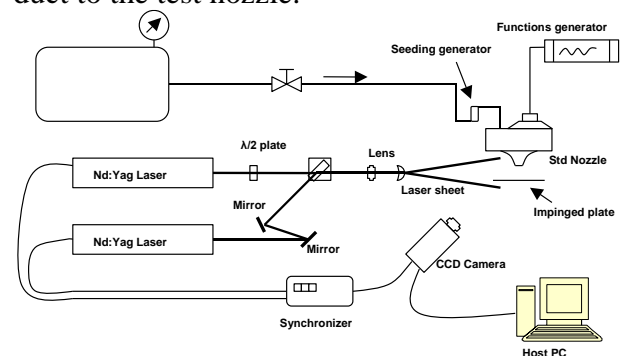

Fig. 1. PIV set-up and system components

The images have been collected by of a double frame 1024 x 1024 pixels PCO CCD

camera synchronized with the two laser beams and with the frame grabber by means of a dedicated electronic synchronizer. The images are formed by two different layers, each of them containing information about the seeding positions obtained by firing one of the two lasers. So the initial seeding positions (first laser beam, image on the first layer) and the final one (second laser beam, image on the second layer) is spotted.

The images were then post-processed by means of the TSI Insight V.3.2 software in order to extract the sub-images formed by 32 X 32 pixels from each layer, and to perform a cross-correlation between the two corresponding sub-images. An interrogation algorithm extracts the correlation peak position from the cross-correlation domain with a sub-pixel precision, and performs the calculation of the two velocity components for those sub-images, by a pixel-to-mm conversion factor. Interrogations are repeated using a recursive algorithm for the entire set of double frames images. The measured velocities are reported in a grid with size of 32 x 32 pixels with a 50% overlap (Nyquist criteria). The two laser beams have been fired at about 100 mJ per pulse (second harmonic), and with separation time of 40 ms. The measurement volume has been stretched up to 1 mm from the impinged plate. The overall estimated error has been evaluated, according to [16 and 17], as about 4% on V_{av} .

In order to measure and keep under a strictly control the imposed Re a simply single component Laser Döppler Velocimetry (LDV) scheme as been adopted. The LDV system, working in forward mode, is constitute by a He-Ne 10 mW CW laser, a beam splitter, a 100% reflection prism and a frontal lent with 300 mm of focal length. The scattered signal is collect with a photomultiplier who send the information at an IFA 655 Burst Analyzer (TSI). The Find (TSI) commercial software as been used in order to collect and elaborate the velocity information. In order to keep the signal-noise ratio as high as possible and a high data rate (~5000 sample/s), the adopted LDV do not use the frequency shift technique so it is not able to resolve the velocity polar ambiguity.

The control volume, arranged for collect the axial velocity components, is positioned on the nozzle axis at two mm below the nozzle exit. The measured axial velocity components were also used for extract the velocity frequency distributions with and without the acoustic activation of the synthetic jet. In Fig. 2 a detail of the annular jet is reported. It's possible to observe the relative position of the cavity and loudspeaker forming the synthetic jet and the converging nozzle.

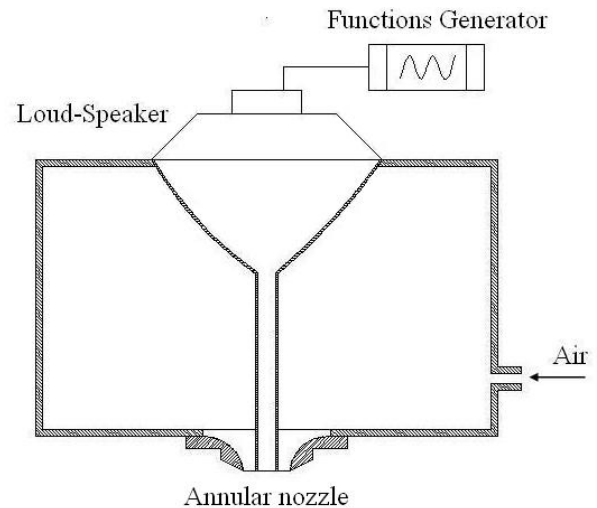

Fig. 2 Detail of the annular nozzle/synthetic jet arrangement.

RESULTS AND DISCUSSION

Different combinations of Re , St and h/d have been explored in the present work: Re equal to 1000 and 1500, St ranging from 0.2 to 0.8; the geometric configurations reported in this paper is $h/d = 2$.

Focalizing the attention at the flow structure carried out by performing PIV measurements for Re 1500 and $h/d = 2$, on the stagnation and wall jet regions for the annular jet under unperturbed discharge condition it is possible to make the following considerations: as aspect the instantaneous velocity field (Fig. 3A and B) reveals an empty internal cone (no gaseous flow) due to the annular configuration of the nozzle with the main flow discharged by the free annulus zone formed by the nozzle and by the tube positioned in the center. With the exception of the initial part of the produced jet, the

behavior of the jet at the impinged surface is not dissimilar from a jet produced by normal convergent nozzle [10]. This situation is confirmed also by the vorticity distribution, reported in Fig. 3C, in which low intensity vorticity is essentially localized on the external surface of the jet. The image reported in Fig. 3C can be used as a reference image in order to infer the effect of the synthetic jet activation visible in Fig. 4A and B, in which are respectively reported PIV image and instantaneous velocity distributions, obtained (at the same Re) in presence of the synthetic jet active by the loudspeaker piloted at an acoustical excitation frequency of 212 Hz (St 0.8). As it is clear visible, the activation of the synthetic jet induces a strong modification in the PIV image and, consequently, in the velocity distribution. In particular several effects have been generated: The first one is the formation of secondary coherent structures like plumes, a sort of secondary jets, located on the external surface of the jet, quite close to the impinged surface, probably induced by the breakdown of the coherent vortex formed on the external surface of the jet and located at about one diameter (10 mm) down from the nozzle discharge section. This kind of vortex, well known and described, naturally present at relatively high Re or induced by jet excitation [10], presents different breakdown mechanism on the impinged surface, compared with the present one. The observed effect is induced by a sort of vortex squashing induced by the axial oscillation produced by the sinusoidal pulsation of the synthetic jet. This pulsation is responsible, also, of another observed effect, the formation of two counter rotating vortices in the central cone in which the synthetic jet act. These vortex represents a sort of “internal” jet expansion in the opposite direction respect the main discharge direction. In Fig. 4C the vorticity distribution highlights all the described effect. The observed coherent structures interact strongly with the impacting surface. In particular the typical stagnation region is quite completely destroyed with obvious modification of heat and mass transfer mechanism. The impinged region is strongly modified, respect at the

usual one, also for low Re . In fact observing the image, obtained at Re 1000 and St 0.3, reported in Fig. 5A and B in which a PIV image and relative velocity distribution are respectively reported, a counter clockwise rotating structure is formed internally the jet, just in correspondence of the impact with the flat surface. The rotating flow field, generated by the flow unbalance induced by the interaction between synthetic and annular jets, prevents the formation of semi-quiescent fluid dynamic condition responsible of the typical relative minimum in transport coefficient distribution [10]. In Fig. 5C it is possible to observe the vorticity distribution with a single vortex positioned at the center of the jet near the impacted plane.

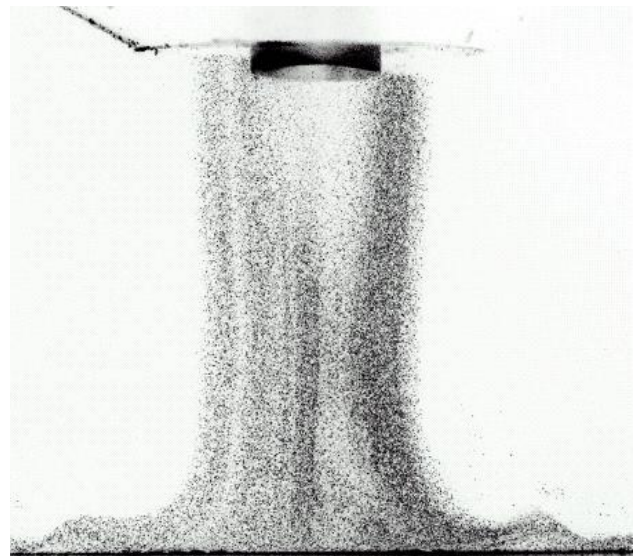

Fig 3A. PIV image of the annular jet without synthetic jet activation. $Re = 1500$ $h/d = 2$.

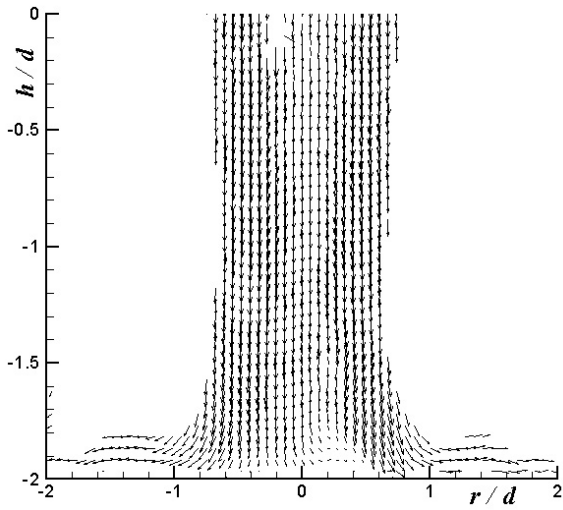

Fig. 3B. PIV velocity distribution of the annular jet without synthetic jet activation. $Re = 1500$ $h/d = 2$.

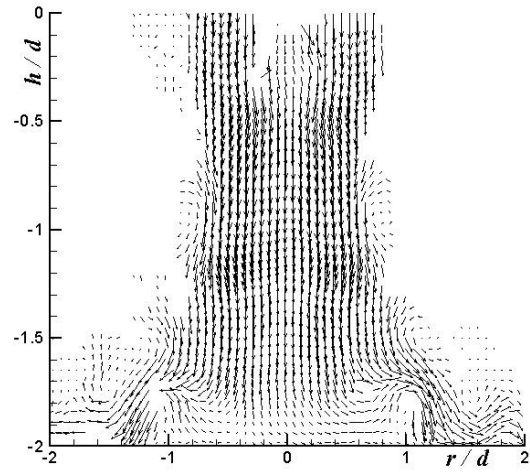

Fig 4B. PIV Velocity distribution at Re 1500, $St = 0.3$, $h/d = 2$.

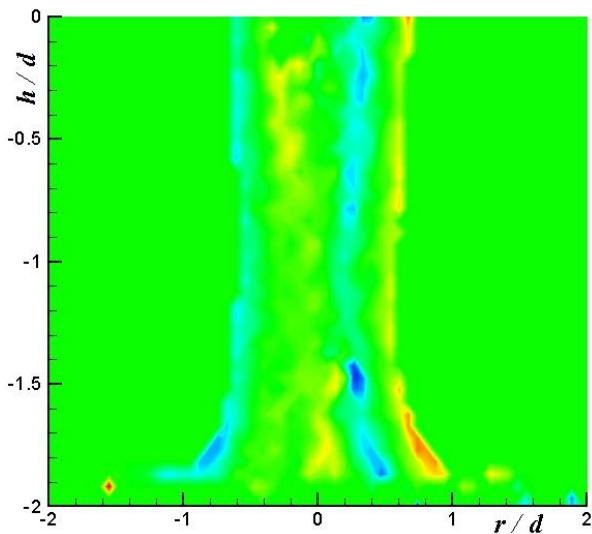

Fig 3C. Vorticity distribution of the annular jet without synthetic jet activation. $Re = 1500$ $h/d = 2$.

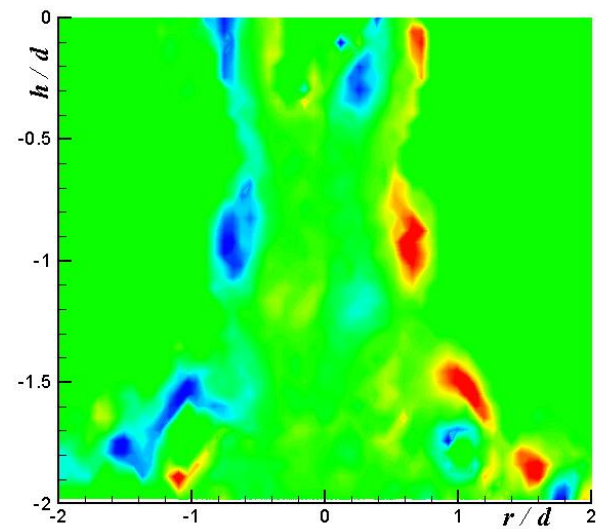

Fig. 4C Vorticity distribution at Re 1500; $h/d = 2$; synthetic jet oscillating at 212 Hz.

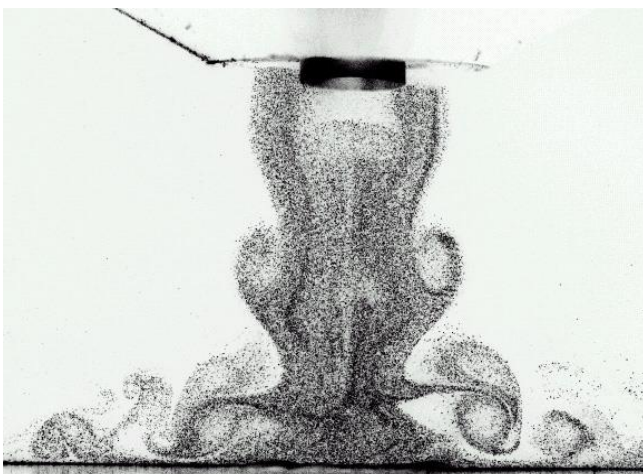

Fig. 4A. PIV image of annular jet at Re 1500, $St = 0.3$, $h/d = 2$.

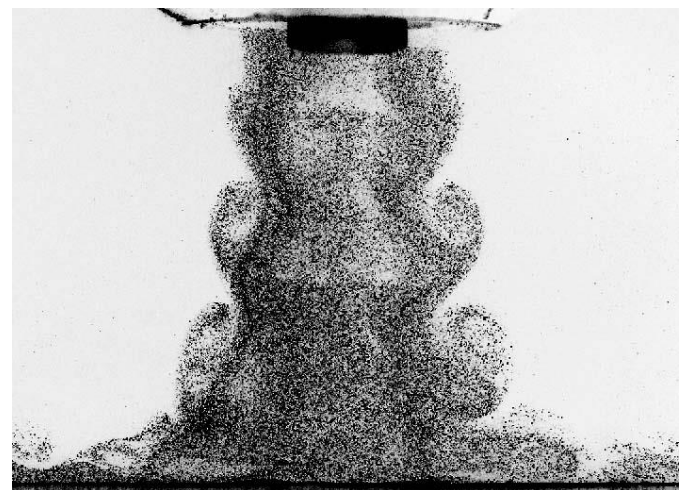

Fig. 5A. PIV image of annular jet at Re 1000, $St = 0.3$, $h/d = 2$.

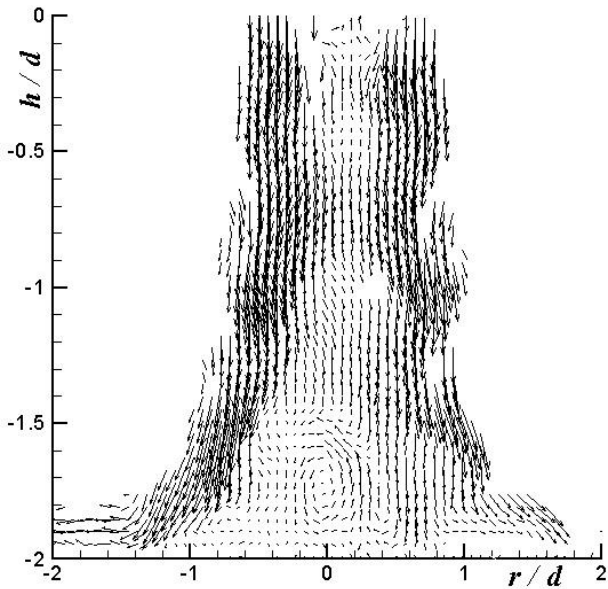

Fig. 5B. Velocity distribution obtained at Re 1000, St 0.3 and h/d 2.

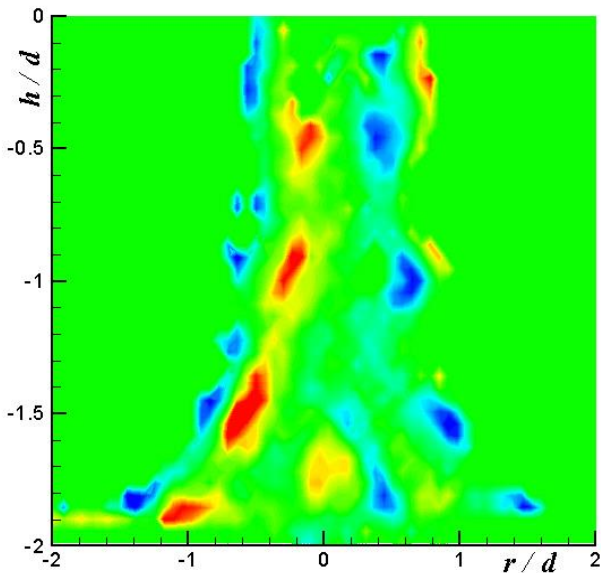

Fig. 5C Vorticity distribution at Re 1000, St 0.3 and h/d 2.

In Fig. 6 it is possible to observe time resolved axial velocity component oscillation, obtained measuring the axial jet velocity component, at 10 mm downstream the nozzle, by means of the LDV technique. In this figure is clear visible the periodicity of the velocity fluctuation with the same frequency of the sinusoidal signal used for feed the loudspeaker forming the synthetic jet. That means that controlling the oscillating frequency of the loudspeaker it is possible to control the periodicity of the velocity oscillation in the annular jet.

The frequency of the axial velocity component oscillation has been used for the St Number calculation.

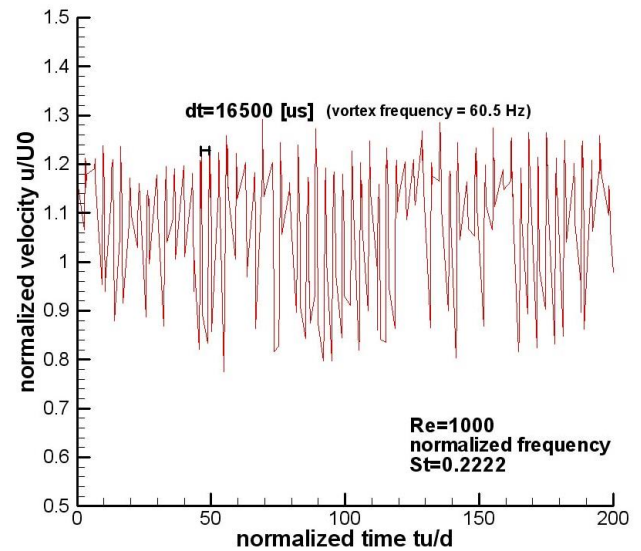

Fig. 6. Time resolved axial velocity component obtained by means of the LDV technique.

CONCLUSIONS

An annular jet exited by mean of a synthetic jet has been investigated, under sinusoidal oscillation at different frequencies, different Re and h/d ratio, by mean Velocity data measurements. The investigations show a hollow conical structure when the synthetic jet is not active and the formation of several coherent structures (vortices) at the activation of the synthetic jet. These coherent structures interact significantly with the impinged surface. The velocity oscillation induced by the synthetic jet perturbation, have been used for the St number calculation.

References

- [1] Ko, N.W.M. and Chan, W.T., Similarity in the initial region of annular jets; three configurations, *J. Fluid Mech.*, 84-4, 641-656 (1978).
- [2] Ko, N.W.M. and Chan, W.T., The inner regions of annular jets, *J. Fluid Mech.*, 93-3, 549-584 (1979).
- [3] Durao, D.F.G. and Whitelaw, J.H., Velocity characteristics of the flow in the near

wake of a disk, *J. of Fluid Mech.*, 85-2, 369-385 (1978).

[4] Glezer, A. and Amitay, M., Synthetic Jets, *Ann. Rev. Fluid Mech.*, **34**, pp.503-529 (2002).

[5] Gilarranz, J. L. and Rediniotis, O. K., Compact, High-Power Synthetic Jet Actuators for Flow Separation Control, *AIAA paper* 2001-0737 (2001).

[6] Smith, B. L. and Glezer, A., Jet Vectoring Using Synthetic Jets, *J. Fluid Mech.*, **458**, pp.1-34 (2002).

[7] Davis, S. A. Glezer, A., Mixing Control of Fuel Jets Using Synthetic Jet Technology: Velocity Field Measurements, *AIAA paper* 99-0447 (1999).

[8] Koso T., Enhanced Mixing of a Circular Jet Using an Annular Synthetic Jet Actuator. *Proceedings of Int. Conference on Jets, Wakes and Separated Flows* 2005. ISBN4-944068-75-1.

[9] Trávníček Z., Tesar V., Annular impinging jet with recirculation zone expanded by acoustic excitation, *Int. J. Heat Mass Transfer*, vol. 47, pp. 2329-2341, 2004.

[10] R. Fasanella, R.M. Di Tommaso, E. Nino "Evaluation of Local Heat Transfer and Visualization of an Impinging Jet Acoustically Perturbed". *Proceedings of Int. Conference on Jets, Wakes and Separated Flows* 2005. ISBN4-944068-75-1.

[11] Vanierschot M. and Van den Bulck E., Planar Pressure Field Determination in the Initial Merging Zone of an Annular Swirling Jet Based on Stereo-PIV Measurements. *Sensors* 2008, **8**, 7596-7608; DOI: 10.3390/s8127596 ISSN 1424-8220.

[12] Tesar V., Trávníček Z., Excitational metamorphosis of surface flowfield under an impinging annular jet. *Chemical Engineering Journal* 144 (2008) 312–316.

[13] O'Connor J., Natarajan S., Malanoski M., Lieuwen T., Disturbance Field Characteristics of a Transversely Excited Annular Jet. *Proceedings of ASME Turbo Expo 2010: Power for Land, Sea and Air GT2010* June 14-18, 2010, Glasgow, UK GT2010-22133

[14] Vanierschot M., Van den Bulck E., Experimental study of low precessing frequencies in the wake of a turbulent annular

jet. *Experiments in Fluids* (2011) 50:189–200 DOI 10.1007/s00348-010-0914-0.

[15] Danlos A., Lalizel G., Patte-Rouland B., Experimental characterization of the initial zone of an annular jet with a very large diameter ratio. *Experiments in Fluids* (2013) 54:1418 DOI 10.1007/s00348-012-1418-x.

[16] Rael M., Willert C., Kompenhans J., *Particle Image Velocimetry*, Springer, Berlin, 1998.

[17] Ullum U., Schmidt J.J., Larsen P.S., McCluskey D.R., Statistical analysis and accuracy of PIV data, in: *Proceedings of the 2nd International Symposium on PIV*, Fukui, Japan, 9–11 July 1997.