



Overview of in-bore pipe cutting and welding tools for the maintenance of CFETR and EU-DEMO

Donato Sorgente^{a,b,*}, Rocco Salvato^a, Christian Bachmann^c, Curt Gliss^c, Günter Janeschitz^d, Hongtao Pan^e, Xinliang Zhou^f, Haoying Wang^g, Rocco Mozzillo^a

^a CREATE, Engineering School of Basilicata University, Campus Macchia Romana (PZ), 85100, Italy

^b Department of Mechanics, Mathematics and Management, Politecnico di Bari, Via Orabona, 4, Bari 70125, Italy

^c FTD Department, EUROfusion Consortium, Boltzmannstr. 2, Garching, Germany

^d Max-Planck-Institut für Plasmaphysik, Garching 85748, Germany

^e Institute of Plasma Physics, Chinese Academy of Sciences, Shushanhu Road 350, P.O.Box 1126, Hefei, Anhui, China

^f HNU College of Mechanical and Vehicle Engineering, Lushan South Road 2, Changsha, Hunan, China

^g School of Mechanical Science and Technology, Huazhong University of Science and Technology, Wuhan 430074, China

ARTICLE INFO

Keywords:

DEMO
CFETR
Remote maintenance
Breeding blanket
Feeding pipes

ABSTRACT

In the remote maintenance of fusion nuclear devices, one of the most challenging tasks is the cutting and the re-welding of large pipes that feed the breeding blanket. The narrow space around some of the pipes hinders the suitability of conventional orbital processes. For such pipes, both the cutting system and the welding one have to be compact enough to move along their interior, lock against the pipe inner wall and keep the position during the operation. The inner diameter and thickness of the pipes together with the other severe requirements related to the remote maintenance drive the choice of the processing technologies and the design of the tooling configuration. In this work, activities carried out by a joint team from EU-DEMO and CFETR on the in-bore cutting and welding operations are presented and discussed. For the in-bore cutting system a solution for the simultaneous parting and bevelling has been developed opting for a mechanical cutting with a pair of symmetrically distributed knives. A preliminary dimensioning of the motors has been made assuming the radial feed and the cutting speed of the knives. For the in-bore welding system, the TIG welding with filler wire has been considered as the most reliable and suitable technology within prescribed requirements and constraints. A multi-pass welding operation has been assumed. A conceptual design of both tools has been developed. The space constraint remains the most critical issue. Further verification and validation work is planned in close collaboration between European laboratories and the Comprehensive Research Facility for Fusion Technology (CRAFT) at ASIPP in Hefei.

1. Introduction

One of the key aspects for the achievement of the goals set by the demonstration fusion nuclear plant DEMO is the achievement of a system for a regular, rapid, and reliable maintenance of the plant. Amongst several challenging engineering tasks that have to be taken into account, there is the remote replacement of a large number of pipes connected to the breeding blanket. In the pre-concept design phase of DEMO, mainly two dimensions of the pipes were proposed, namely the DN90 and the DN200 [1]. These pipes have to be cut and re-weld during the replacement and, the extreme conditions in which the remote maintenance task has to be carried out, require specific technologies and approaches.

There are several requirements, especially in terms of available space, that make conventional tooling not suitable for the specific application [2,3]. In particular, due to space constraints related to the plant architecture, conventional external orbital operations cannot be carried out for some of the pipes to be replaced [4]. Thus, cutting and welding operations have to be done with in-bore tools moving inside the pipe.

The challenge to operate from the interior of the pipe was already faced by researchers in the ROBERTINO facility (heavy robotics facility) who demonstrated the feasibility of such processes for the ITER project [5]. The task was performed by mechanical cutting and tungsten inert gas (TIG) welding on AISI 316 L steel pipes with 50 mm of inner diameter and 2 mm thickness. The tools were locked in position by

* Corresponding author.

E-mail address: donato.sorgente@poliba.it (D. Sorgente).

<https://doi.org/10.1016/j.fusengdes.2024.114478>

Received 20 October 2023; Received in revised form 15 March 2024; Accepted 24 April 2024

Available online 30 April 2024

0920-3796/© 2024 The Author(s). Published by Elsevier B.V. This is an open access article under the CC BY license (<http://creativecommons.org/licenses/by/4.0/>).

means of inflatable plugs [5]. In the framework of the ITER project, a comparative study of TIG and laser welding was also conducted on AISI 316L pipes with 48.26 mm of outer diameter and 2.77 mm thickness. A single pass welding without filler material was performed and the pipes were positioned horizontally. Results of this latter experimental activity showed that both welding technologies were feasible with peculiar benefits and drawbacks of each. In particular, the TIG welding could tolerate higher misalignments and gaps (between the pipes to be butt-joined) than the laser welding could. Also, TIG produced less spattering and fumes. On the opposite, the laser welding tool had a longer lifetime than the TIG one (the electrode should be replaced more frequently) and it allowed using a lower heat input, reducing the heat affected zone and assuring a better re-weldability of the pipe [6]. Laser processing, both for cutting and welding with and without filler material, was also studied for AISI 316L pipes with thickness ranging from 3 mm to 7.6 mm. The use of a filler wire in laser welding allowed to increase the gap tolerance. In laser cutting experiments, a large amount of dross (recast material) below the cut kerf and attached to the pipe wall was reported [7]. In the DEMO scenario, in-bore solutions for cutting and welding of pipes was explored in the development of the Service Joining Strategy [8]. Experimental laser cutting and welding trials on pipes with a 3 mm thickness were conducted both on P91 and AISI 316L steels [9]. Hybrid laser-laser welding was also investigated for P91 and Eurofer97 steels (pipes 6 mm in thickness) to reduce the cooling rate after welding and enhance mechanical performance of the joints [10]. Mechanical cutting was also explored for a AISI 316 L steel pipe with an inner diameter of 42.72 mm and a thickness of 2.77 mm. Both swaging (based on a continuous plastic deformation of the material without swarf production) and machining (by a face mill with six tips) were explored reporting, in both cases, a good surface finish suitable for subsequent welding [11].

While the relatively small diameter of the DN90 pipes represents a critical aspect in terms of space constraints for in-bore cutting and welding operations, the relatively large thickness (15-16 mm) of the largest pipe (DN200) set other challenges for making those operations feasible, reliable and accurate enough. While conventional cutting and welding of such thicknesses is reported in literature, the specific working configuration in the DEMO architecture, requires *ad hoc* designed equipment.

The aim of this work is to identifying potential technologies and tooling for in-bore cutting and welding of the large pipes developing a conceptual design based on the effective conditions in which the cutting and the welding tools have to operate. In this article, the work is focused on DN200 pipes and the authors report results achieved within the collaboration between European laboratories and the Comprehensive Research Facility for Fusion Technology (CRAFT) at ASIPP in Hefei, China.

2. Requirements, boundary conditions and assumptions

In the remote replacement of pipes, main requirements for the cutting and welding operations and for the related tooling can be summarized as follows:

- reliability of the processes and of the equipment
- recoverability with no personnel access
- minimal or no debris
- minimal processing time
- cut and weld as close as possible to the blanket segment
- no assisting fluid that leaves residual contaminants
- parallel cutting and welding operations (on more than one pipe a time)
- cutting: sufficient edge quality and suitable kerf geometry for subsequent welding
- welding: minimal thermal distortion, sufficient gap and misalignment tolerance, structural integrity of the weld seam.

The abovementioned requirements lead in themselves to very restrictive conditions in which all the designed systems have to operate. Nevertheless, the boundary conditions strictly related to the nuclear plant environment put further constraints in terms of eligible cutting and welding technologies as well as for feasible electro-mechanical systems that have to drive the tools before, during and after the parting and joining processes. For instance, radiation tolerant materials have to be chosen considering the overall exposition time related to the remote maintenance operations involving a specific component of the system, since the radiation dose rate after the machine shutdown is not negligible [12]. As already mentioned in the introduction, the need to act from the interior of a pipe set very stringent space constraints. As Fig. 1 shows, a “pipe forest” has to be removed and, this operation requires orbital cutting as well as in-bore cutting operations to separate permanent pipes from the ones that should be replaced [13].

In this scenario, the presented work focusses on DN200 pipes, assuming a wall thickness of 16 mm made of AISI 316 L steel. The maintenance sequence involves the pipe caps removal in their upper end by means of a dedicated transporter. Thus, for both the cutting and the welding tools a straight pipe to be entered and processed was considered assuming a simple deployment system able to drive the tools in position on a straight portion of the pipe. No pipe alignment system was designed for the welding operation since an external conical coupling was assumed on the external wall of the pipes [13]. Main assumptions on process parameters (cutting speed, feed rate, welding speed to cite a few of them) are related to similar application and similar materials to be machined due to the lack of specific data for the particular application [14,15]. Also, the chip evacuation and collection during the cutting operation was assumed taking into account similar applications but having no data for the specific processing configuration.

In Fig. 2, a schematic representation of the cutting and welding configurations is reported.

The calculation of the material to be removed (by mechanical cutting) and the one to be filled during welding takes into account the reuse of the upper part of the pipe and the disposal of the lower part (connected to the breeding blanket). For this reason, the bevel angle (for weld preparation) is created during the cutting only on the upper part of the pipe while the lower part, after replacement, is thought to be put in place with a bevel already created on the new pipe connected to the new breeding blanket segment.

3. In-bore cutting tool

Due to the large thickness of the DN200 pipe, swaging was not considered as a viable solution since the plastic deformation of such pipe walls would require too large forces to be achieved with an in-bore tool. Laser cutting was also excluded for this cutting operation due to the

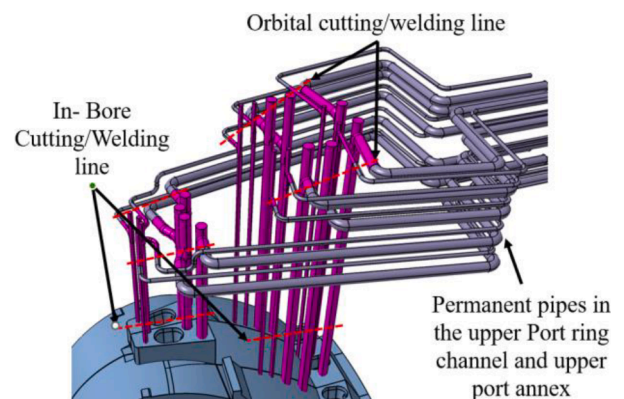

Fig. 1. Permanent pipes (in grey) and pipes to be removed (in magenta) during the remote maintenance task. Both orbital (from the exterior) and in-bore (from the interior) cutting were assumed.

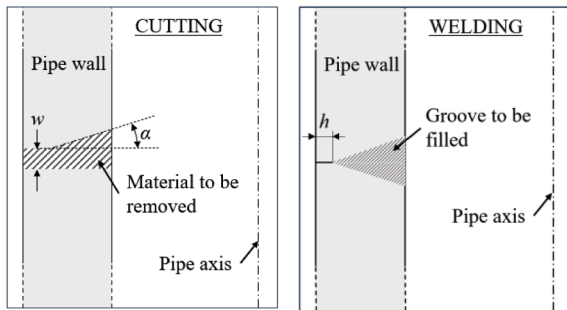

Fig. 2. Schematic of the material to be removed by cutting and to be filled by welding (Not To Scale).

difficulty in reaching a level of sufficient quality for subsequent welding, to the potential risk of having a large droop on the external side of the pipe and to the large amount of laser power needed for such a thickness value. In the developed conceptual design, the severing process of the pipe involves a progressive mechanical cutting in which a simultaneous parting and bevelling operation is carried out starting from the inside diameter (ID) and ending on the outside diameter (OD). A couple of tool bits (one for the parting and one for the bevelling) are positioned on the opposite sides of a rotating cross with an automatic feeding system (similar to the one commonly used in orbital pipe cutting) that allows them to move outward in the radial direction. Even though the tool bits, the tool holders and the feeding system have not been designed yet, the required space for their positioning is guaranteed by the available length of the arms of the rotating cross on which all the cutting system can be installed and along which the feeding can be applied. The position of the parting tool bit along the pipe axis is slightly offset with respect to the bevelling one in order to create a Y-shaped cut edge only on the upper part of the pipe (see Fig. 2).

All the system is kept in position by a double supporting system acting against the pipe inner walls with three contact pads each, moving radially outward to engage the pipe internal walls. The position system is driven by a vertical actuator located in the upper part of the system (Fig. 3a).

A preliminary dimensioning of the motors driving the cutting tools was made assuming the radial feed and the cutting speed and calculating the cutting force and the required torque based on the material properties and the cross (undeformed) section of the resulting chip. Several configurations of process parameters were considered following a conservative approach. Main pieces of information that are still missing to remove some uncertainties on the cutting operation are actual process parameters and cutting conditions: optimal values of the cutting speed for simultaneous parting and bevelling from the ID to the OD, of the radial feed rate, of the width of the parting tool, type and movement of the chip, tool life/wear in the specific geometrical configuration and in dry cut conditions or with air cooling. An air diffuser (Fig. 3c) to push down the chips and cool down the cutting area was designed. As already said, no cutting fluids shall be used to avoid contaminations of the area.

Starting from data related to process parameters adopted in similar orbital cutting operations, a cutting force in the order of 10^3 N, a cutting torque of approximately 400 Nm and a net power of 3 kW were estimated. In order to achieve such performances, commercially available electric motors appeared to be not compact enough to work inside a DN200 pipe. Thus, three pneumatic motors in a 120° configuration (Fig. 4) were considered and an internal cylindrical gear was dimensioned to fulfil the torque requirement on the rotating cross where the tool bits shall be mounted (Fig. 3d). Pneumatic motors are already used for conventional orbital operations and are commonly controlled by regulating the pressure and the flow of compressed air, which in turn affect the power and the rotating speed. A detail of the reduction gear is depicted in Fig. 5.

With the assumptions made, the volume of the material to be

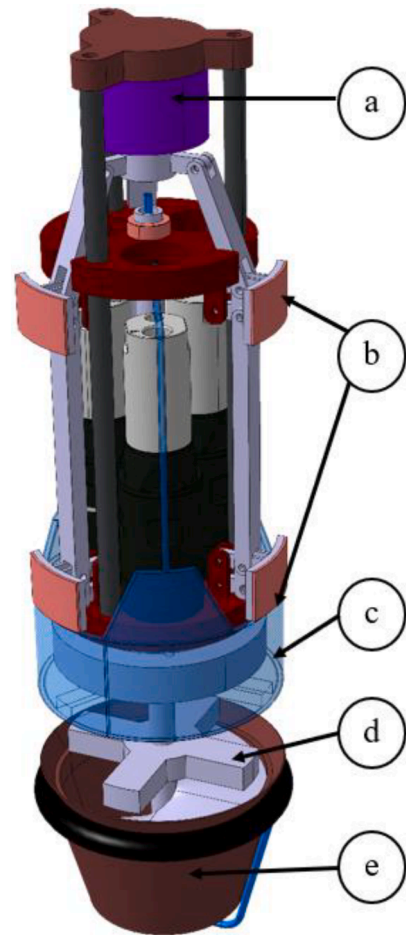

Fig. 3. Cutting system for in-bore operation and main components: (a) pneumatic cylinder to engage the friction pads, (b) friction pads of the supporting system, (c) air diffuser to push down the chips and cool down the cutting area, (d) cutting cross on which cutting tool bits and the feeding system are located (not drawn), (e) chip collector with air cushion and screw compactor. The three pneumatic motors are in grey and blank in the central part of the system.

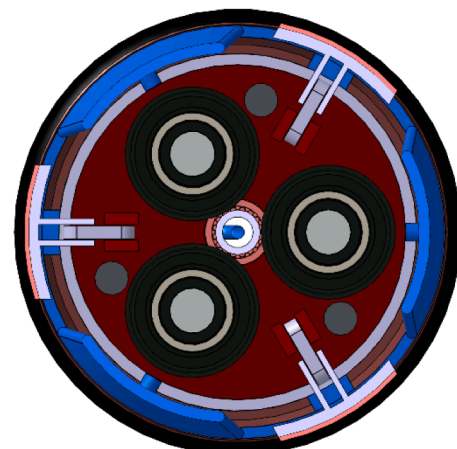

Fig. 4. Section of the cutting system with the three motors in a 120° configuration.

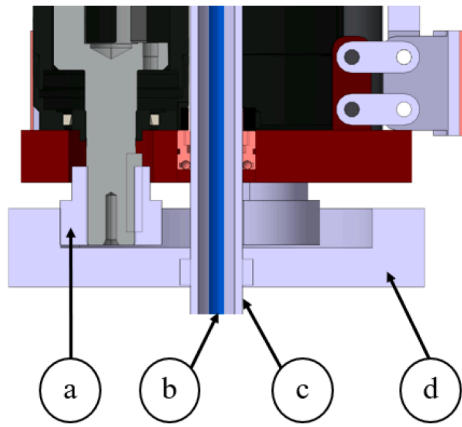

Fig. 5. Detail of the reduction gear of the cutting system: (a) pinion (one of three), (b) air cushion feeding pipe, (c) hollow shaft, (d) internal cylindrical gear.

removed V_R during the cutting operation can be calculated by Eq. (1):

$$V_R = \pi \left\{ \frac{OD^2 - ID^2}{4} w + \left[\frac{1}{3} \left(\frac{OD}{2} - h \right)^3 - \frac{1}{3} \left(\frac{ID}{2} \right)^3 + - \frac{ID^2}{4} (t - h) \right] \tan \alpha \right\} \quad (1)$$

where w is the width of the parting tool, h is the height of the bevel root, t is the thickness of the pipe and α is the bevel angle. Assuming feasible values of w , h and α , a value of V_R in the range 8.0×10^4 and 1.0×10^5 mm³, that corresponds to a removed mass of approximately 800 g for each pipe, was estimated.

This mass is the same that shall be collected, for each pipe, in chip form and that occupies a significantly higher volume than V_R . A chip/debris collector with a screw compactor was then designed in the lower end of the system, able to engage the internal pipe walls and to constraint its rotation by means of an inflatable annular air cushion (Fig. 3e).

4. In-bore welding tool

The correct implementation of the welding process after the cutting and the replacement of the pipes is critical since, after this joining operation, the pipe should be able to fulfil its function into operation with the required performances. For this reason, after welding, non-destructive testing of the weld is considered as a necessary step and a separate device (potentially integrated with the welding system) should be designed; however, the design of this device is out of the scope of this work and it is not considered in the current design of the welding tool. Nevertheless, the need of achieving a weld seam of sufficient quality remains. The choice of the welding technology was driven by quality aspects as well as by the feasibility of adopting an in-bore tool able to create the joint within the boundary conditions already mentioned in previous section. Several technologies have been investigated for the welding of AISI 316L(N) steel [16]. The use of laser has already been reported extensively for relatively small thicknesses in nuclear applications but the technology could be used also for larger thicknesses even without filler material [17,18]. Fang et al. [19] reported that a plate 15 mm in thickness was successfully welded using laser on an ITER-grade austenitic stainless steel (AISI 316LN) in a single pass and without a filler wire. TIG welding, also known as Gas Tungsten Arc Welding (GTAW), is a well-known and established technology for joining austenitic stainless steel with high quality of welds, relatively low distortions induced in the material if compared to other arc welding technologies [15]. TIG welding brings also benefits in terms of minimum spattering produced together with a relatively wide tolerance to gap and misalignment in butt joints if compared to laser welding. For the

conceptual design of the welding tool, TIG was considered as the most reliable and suitable technology within prescribed requirements and constraints. Due to the relatively large thickness of the pipe wall, a multi-pass welding operation was assumed. The first pass should create a weld bead along the root in the Y-shaped groove with a minimum penetration depth equal to h (Fig. 2). Subsequent passes shall fill the groove with a specific torch trajectory that varies in each welding pass. In fact, in order to correctly move into the groove, the tungsten tip should not only rotate around the pipe axis but it should move also along the axial and the radial directions. To allow a 360° continuous rotation, a rotary manifold for the shielding gas, the cooling water for the torch, the electric power was designed (Fig. 6e) starting from *off-the-shelf* components already available on the market. In Fig. 7a detail view of the lower end of the welding tool is depicted.

The volume V_F to be filled by filler material in the groove created by the bevelling operation (Fig. 1) can be calculated according to Eq. (2):

$$V_F = 2\pi \left[\frac{1}{3} \left(\frac{OD}{2} - h \right)^3 - \frac{1}{3} \left(\frac{ID}{2} \right)^3 - \frac{ID^2}{4} (t - h) \right] \tan \alpha \quad (2)$$

where all the symbols have the same meaning used in Eq. (1) for the cutting tool. For each pipe, a mass of approximately 600 g of filler material is required that corresponds to approximately 90 m of a filler wire with a 1 mm diameter. The capacity of conventional spools for welding operation with a feasible diameter (smaller than the pipe ID) is too small if the welding tool has to work for more than one pipe. For this

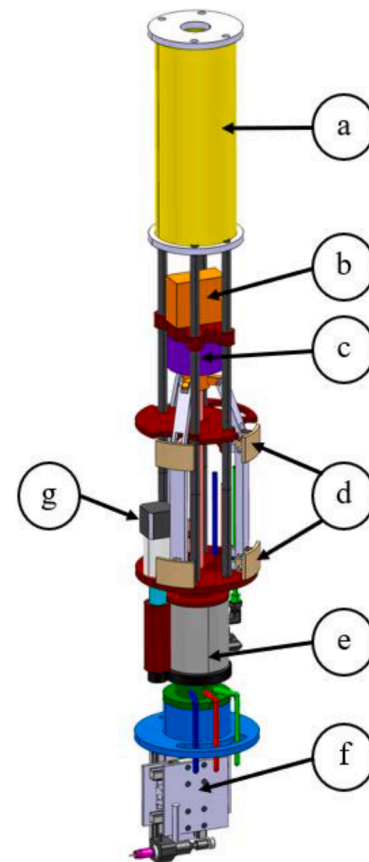

Fig. 6. Welding system for in-bore operation and main components: (a) drum for filler wire, (b) wire feeder, (c) electric motor for pushing the friction pads against the pipe inner wall, (d) supporting unit (6 friction pads), (e) rotary manifold for electric supply, cooling water and assisting gas, (f) motion system for radial and axial translation of the torch, (g) electric motor for axial rotation of the welding torch. The design of the nozzle for the filler wire is under development and is not depicted in this figure.

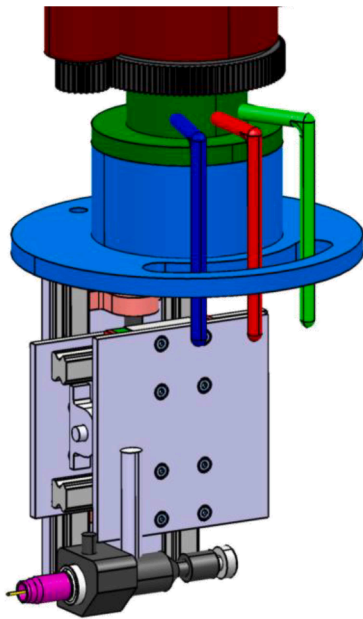

Fig. 7. Detail of the welding torch and the motorized motion system to allow the tip of the torch.

reason, a drum (Fig. 6a) for the filler wire was designed in the upper part of the system. A motorized wire feeder (Fig. 6b) shall provide the wire to the torch on the opposite end of the system.

For engaging the system against the pipe inner walls and keeping it in position during the welding process, a supporting unit similar to the cutting tool was designed (Fig. 6d) with an electric actuator to engage the friction pads.

Calculations about the needed electric power is under development assuming a welding current around 200 A and a voltage around 10–15 V. Besides the net electric power at the welding torch, auxiliary systems with their required power have to be considered. Main auxiliary systems are (i) a chiller for the cooling water running through the welding torch, (ii) the motion system (for rotation around the pipe axis and translation along the pipe axis and in the radial direction), (iii) the wire feeder and (iv) the hot wire system to increase the deposition rate (v) the shielding gas delivery system and (vi) a real time monitoring of the welding process (for example seam tracking, temperature measurement).

5. Concluding remarks

Two conceptual designs for the in-bore cutting tool and for the in-bore welding tool have been developed for DN200 pipes. Mechanical cutting and arc welding have been chosen as candidate processing technologies in the DEMO scenario within the prescribed boundary conditions.

The two designs need further work to cover some open issues. Critical aspects are mainly related to the lack of specific information and technical commercially available solutions for the particular application. To refine the designs, several uncertainties have to be solved and first prototypes of the tools, even in a simpler configuration than the real one, could help in achieving this goal. The design activities are still in progress to address the structural integrity and behaviour of the tools during the tasks. Moreover, test prototypes are needed to address the design feasibility and to collect experimental data for future reliability analyses. Once these data will be available, further design refinement steps will be performed, also in terms of the final choice of the typology of the motors (pneumatic or electric) according to a more accurate estimation of the needed torque for the IBCT.

The prototyping activities already programmed are also aimed at designing and testing a control system able to manage the in-bore tools.

While the solution proposed can be scaled up for working with larger thicknesses and larger pipe diameters, for smaller diameter and thickness values, for instance for the DN90 pipes, other solutions are under investigation since different solution can be adopted for smaller thicknesses even with a stricter space constraint.

CRedit authorship contribution statement

Donato Sorgente: Conceptualization, Formal analysis, Methodology, Writing – original draft, Writing – review & editing. **Rocco Salvato:** Investigation, Conceptualization. **Christian Bachmann:** Supervision. **Curt Gliss:** Resources. **Günter Janeschitz:** Supervision. **Hongtao Pan:** Resources. **Xinliang Zhou:** Resources. **Haoying Wang:** Resources. **Rocco Mozzillo:** Conceptualization, Software, Supervision, Visualization.

Declaration of competing interest

The authors declare that they have no known competing financial interests or personal relationships that could have appeared to influence the work reported in this paper.

Data availability

Data will be made available on request.

Acknowledgments

This work has been carried out within the framework of the EUROfusion Consortium, funded by the European Union via the Euratom Research and Training Programme (Grant Agreement No 101052200 — EUROfusion). Views and opinions expressed are however those of the author(s) only and do not necessarily reflect those of the European Union or the European Commission. Neither the European Union nor the European Commission can be held responsible for them. The authors wish to thank Antonio Di Giacomo, Claudio Cascini and Vincenzo Claps for their precious help in the development of the CAD models.

References

- [1] O. Crofts, A. Loving, M. Torrance, S. Budden, B. Drumm, T. Tremethick, D. Chauvin, M. Siuko, W. Brace, V. Milushev, M. Mittwollen, T. Lehmann, F. Rauscher, G. Fischer, P. Pagani, Y. Wang, C. Baars, A. Vale, EU DEMO remote maintenance system development during the pre-concept design phase, *Fusion Eng. Des.* 113121 (2022) 179.
- [2] C. Bachmann, C. Gliss, G. Janeschitz, T. Steinbacher, R. Mozzillo, Conceptual study of the remote maintenance of the DEMO breeding blanket, *Fusion Eng. Des.* 113077 (2022) 177.
- [3] C. Bachmann, F. Arbeiter, L.V. Boccacini, M. Coleman, G. Federici, U. Fischer, R. Kemp, F. Maviglia, G. Mazzone, P. Pereslavtsev, R. Roccella, N. Taylor, R. Villari, F. Villone, R. Wenninger, J.H. You, Issues and strategies for DEMO in-vessel component integration, *Fusion Eng. Des.* 112 (2016) 527–534.
- [4] R. Mozzillo, C. Vorpahl, C. Bachmann, F.A. Hernández, A. Del Nevo, European DEMO fusion reactor: design and integration of the breeding blanket feeding pipes, *Energies* 16 (16) (2023) 5058, 2023Page5058.
- [5] F. Andritsos, C. Damiani, F. Farfaletti-Casali, D. Maisonnier, G. Mercurio, E. Ruiz-Morales, Simulation and experimental validation of first wall/blanket assembly and maintenance for the next step fusion reactor, *Fusion Eng. Des.* 42 (1998) 473–484.
- [6] H. Tanigawa, A. Aburadani, S. Shigematsu, N. Takeda, S. Kakudate, S. Mori, T. Jokinen, M. Merola, Comparative study of laser and TIG welding for application to ITER blanket hydraulic connection, *Fusion Eng. Des.* 87 (2012) 999–1003.
- [7] K. Oka, A. Ito, K. Taguchi, Y. Takiguchi, H. Takahashi, E. Tada, Development of pipe welding, cutting & inspection tools for the ITER blanket. Japan Atomic Energy Research Institute, 1999. Available, <https://iss.fnal.gov/archive/other/jaeri-tech-99-048.pdf> (Accessed: -April 26, 2024).
- [8] T. Tremethick, S. Kirk, K. Keogh, A. O'hare, E. Harford, B. Quirk, Service joining strategy for the EU DEMO, *Fusion Eng. Des.* 111724 (2020) (2020) 158.
- [9] S. Kirk, K. Keogh, L. Naidu, T. Tremethick, In-bore robotic laser cutting and welding tools for nuclear fusion reactors, *Lasers Eng.* 46 (2020) 295–304.
- [10] S. Kirk, W. Suder, K. Keogh, T. Tremethick, A. Loving, Laser welding of fusion relevant steels for the European DEMO, *Fusion Eng. Des.* 136 (2018) 612–616.

- [11] S. Shigematsu, H. Tanigawa, A. Aburadani, N. Takeda, S. Kakudate, S. Mori, M. Nakahira, R. Raffray, M. Merola, Verification test results of a cutting technique for the ITER blanket cooling pipes, *Fusion Eng. Des.* 87 (2012) 1218–1223.
- [12] C. Bachmann, S. Ciattaglia, F. Cisondi, T. Eade, G. Federici, U. Fischer, T. Franke, C. Gliss, F. Hernandez, J. Keep, M. Loughlin, F. Maviglia, F. Moro, J. Morris, P. Pereslavtsev, N. Taylor, Z. Vizvary, R. Wenninger, Overview over DEMO design integration challenges and their impact on component design concepts, *Fusion Eng. Des.* 136 (2018) (2018) 87–95.
- [13] R. Mozzillo, C. Bachmann, G. Janeschitz, V. Claps, O.C. Garrido, H. Pan, F. Lif, D. Sorgente, Replacement strategy of the EU-DEMO and CFETR breeding blanket pipes, *Fusion Eng. Des.* 202 (2024) 114311.
- [14] ASM Handbook Volume 16: Machining, ASM International, 1989. ISBN: 978-0-87170-022-3.
- [15] ASM Handbook Volume 6: Welding, Brazing, and Soldering, ASM International, 1993. ISBN: 978-0-87170-382-8.
- [16] H. Kumar, A. Somireddy, K. Gururaj, A review on critical aspects of 316ln austenitic stainless steel weldability, *Int. J. Mater. Sci. Appl.* 1 (1) (2012) 1.
- [17] C. Fang, Y. Song, W. Wu, J. Wei, S. Zhang, H. Li, N. Dolgetta, P. Libeyre, C. Cormany, S. Sgobba, The laser welding with hot wire of 316LN thick plate applied on ITER correction coil case, *J. Fusion Energy* 33 (2014) 752–758.
- [18] X. Zhang, E. Ashida, S. Tarasawa, Y. Anma, M. Okada, S. Katayama, M. Mizutani, Welding of thick stainless steel plates up to 50 mm with high brightness lasers, *J. Laser Appl.* 23 (022002) (2011), <https://doi.org/10.2351/1.3567961>.
- [19] C. Fang, J. Wei, J. Liu, Solidification cracking sensibility of narrow gap laser welding on ITER-grade austenitic stainless steel, *Fusion Eng. Des.* 162 (2021) 112068.